

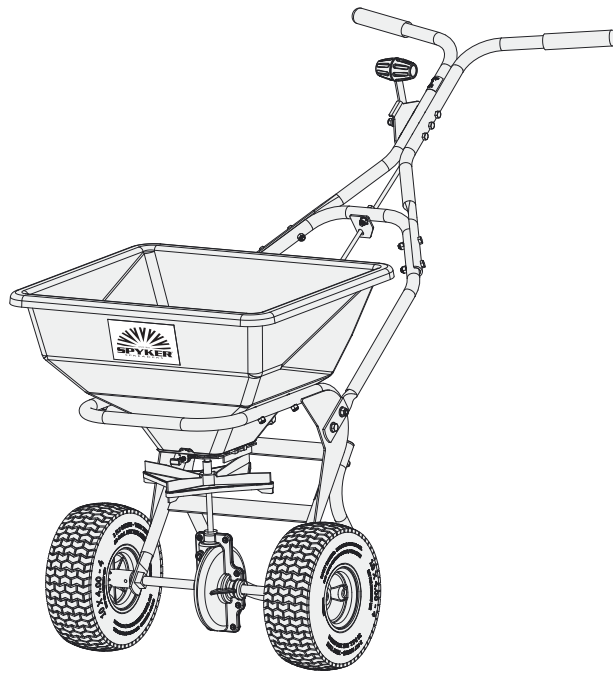

# OPERATOR'S MANUAL

Model SPY50-1P / SPY50L-1P Push Spreader



## Spyker Spreaders

Contact us at 800.972.6130  
[www.spyker.com](http://www.spyker.com)

### **▲ IMPORTANT**

**This manual contains information for the safety of persons and property.  
Read it carefully before assembly and operation of the equipment!**

**TABLE OF CONTENTS**

Safety . . . . . 2  
Part List . . . . . 3  
Hardware Identifier . . . . . 4  
Part Explosions . . . . . 5-7  
  
Assembly . . . . . 8-14  
  
Calibration . . . . . 15-17  
Operation Instructions . . . . . 18-19  
Dial Settings . . . . . 20  
Grass Seed Spreading Chart . . . . . 21  
  
Troubleshooting . . . . . 22  
Warranty . . . . . 24

**OPERATE SAFELY**

**Read Before Using:**

- Keep bystanders away when you operate this machine.
- Use this machine for intended purpose only.
- Do not let children or an untrained person operate machine.
- Keep all parts in good condition and properly installed. Fix damaged parts immediately. Replace worn or broken parts.
- Do not modify the machine or safety devices. Unauthorized modifications to the machine may impair its function and safety, and void the warranty.
- Do not let anyone sit or ride on equipment during operation.
- Wear substantial footwear and long trousers. Do not operate the equipment when barefoot or wearing open sandals.
- Do not wear loose fitting clothing that can get caught in moving parts.
- Always wear eye protection when operating the equipment.
- Stay alert for holes in the terrain and other hidden hazards.
- Watch out for traffic when crossing or near roadways.
- Before you operate any feature of this machine, observe your surroundings and look for bystanders.
- Always wash hands after contact with fertilizers and pesticides.
- Keep all nuts, bolts and screws tight to be sure the equipment is in safe working condition.
- Always remove material from hopper before attaching spreader on a vehicle-mounted spreader caddy.

# Part List

DO NOT RETURN PRODUCT IF YOU ARE MISSING PARTS. PLEASE CALL: 1 (800) 972-6130





No.	Part #	Qty	Description
1	1006084	5	Bolt, HexHd 1/4 x 3/4 SS
2	1001554	9	Washer, Nylon
3	1005198	23	Nut, NylonLock 1/4-20, SS
4	1017543	1	Plate, Linkage
5	1017501	1	Bracket, Linkage
6	1001533	2	Nylon Flange Bushing
7	1017340	1	Control Linkage Assembly
8	1001255	1	Screw 1/4-20 x 1" HexHd,SS
9	1017551	1	Bolt,HexHd 1/4-20 x 1.50
10	1017503	1	Spring, Gate
11	1008431	1	Rate Gate Link, Formed
12	1017580	1	Plate, Hopper Bottom
13	1000203	1	Hopper Bottom Bearing
14	1004880	4	Bolt, HexHd 1/4 x 1/2 SS
15	1001521	2	Guide, Rate Gate/Accuway
16	1000210	1	Rate Gate
17	1001523	1	Accuway Diffuser
18	1001525	1	Accuway Adj. Nut Bracket
19	1001526	1	Accuway Adjustment Screw
20	1000215	1	Pine Tree Clip
21	1000211	1	Dial Mount
22	1000213	1	Dial, Plastic
23	1000198	2	Felt Washer
24	1000051	1	Spreading Spinner
25	1000223	1	Agitator Wire
26	1017420	1	Spinner Shaft, 50 Lb
27	1000054	1	Roll Pin 1/8 x 7/8
28	1001301	2	3/8 Spinner Shaft Bushing
29	1001518	1	Pinion Gear - Metal
30	1001299	2	Gearbox Bushing 5/8"
31	1017421	1	Axle, Wheel SS (SPY50-1P)
	1018126	1	Axle, Wheel SS (SPY50L-1P)
32	1001304	1	Dowel Pin, 3/16 x 1, SS
33	1001516	1	Bevel Gear-metal
34	1005389	1	Nylon Spacer, Pin Retain
35	1005336	1	Gear Box Cover Front
36	1005368	1	Grease Zerk 1/4 Drive IN
37	1017710	8	Bolt, PhlpHd 10-24 x 5/8" SS
38	1005337	1	Gear Box Cover Rear
39	1001308	8	Nut, NylonLock, #10-24 SS
40	1000225	2	Handle Grip

No.	Part #	Qty	Description
41	1017616	1	Weldment, Handle
42	1000000	1	On-off Decal
43	1001351	7	Washer, 1/4" SS
44	1007888	4	Bolt, HexHd, 1/4 x 2-1/4 SS
45	1017371	1	Bolt, HexHd, 1/4 x 3-1/4 SS
46	1001262	10	Bolt, HexHd, 1/4 x 1-1/2 SS
47	1017617	1	Plate, Guide
48	1007828	2	Knob, Handle
49	1017346	1	Spring, Control Lever
50	1017345	1	Lever, Control
51	1017502	1	Linkage
52	1017614	1	Handle, Lower
53	1001315	4	Nut, NylonLock 5/16-18
54	45M1111SS	6	Washer, Flat, SS-5/16"
55	1008811	2	Bolt, Hex 5/16-18 x 1 SS316
56	1017374	2	Bolt, Carriage, 5/16 x 3/4
57	1017504	2	Cap, Plastic
58	L-1744-6	1	Label, Serial#, Spyker
59	1017410	1	Medium Frame Weldment, PC
60	1017415	1	Stand, Med Frame, PC (SPY50-1P)
	1018125	1	Stand, Med Frame, PC (SPY50L-1P)
61	1005414	1	Rue Ring Locking Pin
62	1001350	5	Washer, Flat SS
63	1008027	2	Wheel, 10" (SPY50-1P)
	1001607	2	Wheel, 13" (SPY50L-1P)
64	F-283	2	Bearing, Axle
65	1017432	1	Clevis Pin, 3/16 x 1-1/2 (SPY50-1P)
	1001274	1	Clevis Pin, 3/16 x 1-3/4 (SPY50L-1P)
66	1005367	1	Hair Pin, SS Pivot Mount
67	1017628	1	Manual
68	1017577	1	Cover, Hopper 50#
69	1017545	1	Screen, 50#
70	1017549	1	Hopper, 50#
71	1001386	1	Spyker Accuway Label
72	1008067	1	Decal Spyker Square Blue
73	1017344	1	Control Lever Stop
74	1000053	1	Roll Pin, 1/8 x 3/4
75	1017730	1	Spacer, Plastic
76	1017725	2	Lock Washer Ext/Int Tooth 5/16
77	1017776	1	Support Bracket

# Hardware Identifier

DO NOT RETURN PRODUCT IF YOU ARE MISSING PARTS. PLEASE CALL: 1 (800) 972-6130

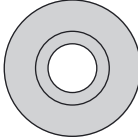
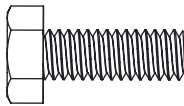
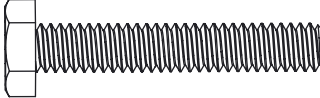
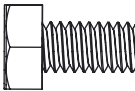
ILLUSTRATIONS ON THIS PAGE ARE TO SCALE FOR FASTER IDENTIFICATION OF HARDWARE DURING ASSEMBLY.

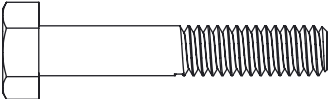
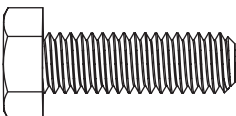
- 3 Nut: Nylon Lock  
1/4"-20 (x23) .....   
**1005198**
- 39 Nut: Nylon Lock, SS  
#10-24 (x8) .....   
**1001308**
- 53 Nut: Nylon Lock  
5/16"-18 (x4) .....   
**1001315**
- 6 Flange Bushing  
Nylon (x2) .....   
**1001533**
- 1 Bolt: Hex Head, SS  
1/4 x 3/4" (x5) .....   
**1006084**
- 9 Bolt: Hex Head  
1/4-20 x 1.50 (x1) ..   
**1017551**
- 14 Bolt: Hex Head, SS  
1/4 x 1/2" (x4) .....   
**1004880**
- 44 Bolt: Hex Head, SS  
1/4 x 2-1/4" (x4) .....   
**1007888**
- 45 Bolt: Hex Head, SS  
1/4 x 3-1/4" (x1) .....   
**1017371**
- 46 Bolt: Hex Head, SS  
1/4 x 1-1/2" (x10) .....   
**1001262**
- 55 Bolt: Hex Head, SS  
5/16-18 x 1" (x2) .....   
**1008811**

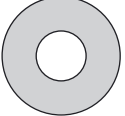
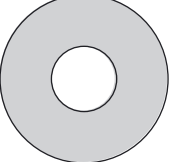
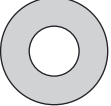
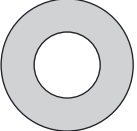
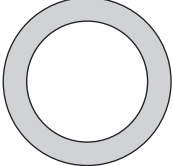
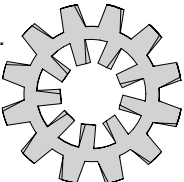
- 2 Washer  
Nylon (x10) .....   
**1001554**
- 23 Washer:  
Felt (x2) .....   
**1000198**
- 43 Washer  
SS 1/4" (x7) .....   
**1001351**
- 54 Washer: Flat  
SS 5/16" (x6) .....   
**45M1111SS**
- 62 Washer: Flat  
SS (x5) .....   
**1001350**
- 76 Lock Washer: 5/16  
Ext/Int Tooth (x2) .....   
**1017225**

\*Exterior circumference of washers can vary. These dimensions are a measurement of the internal diameter of the washer.

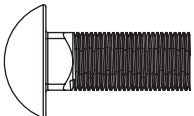
- 56 Bolt: Carriage  
5/16 x 3/4" (x2) .....   
**1017374**



# Part Explosions

DO NOT RETURN PRODUCT IF YOU ARE MISSING PARTS. PLEASE CALL: 1 (800) 972-6130

## RATE GATE + AXLE / SPINNER

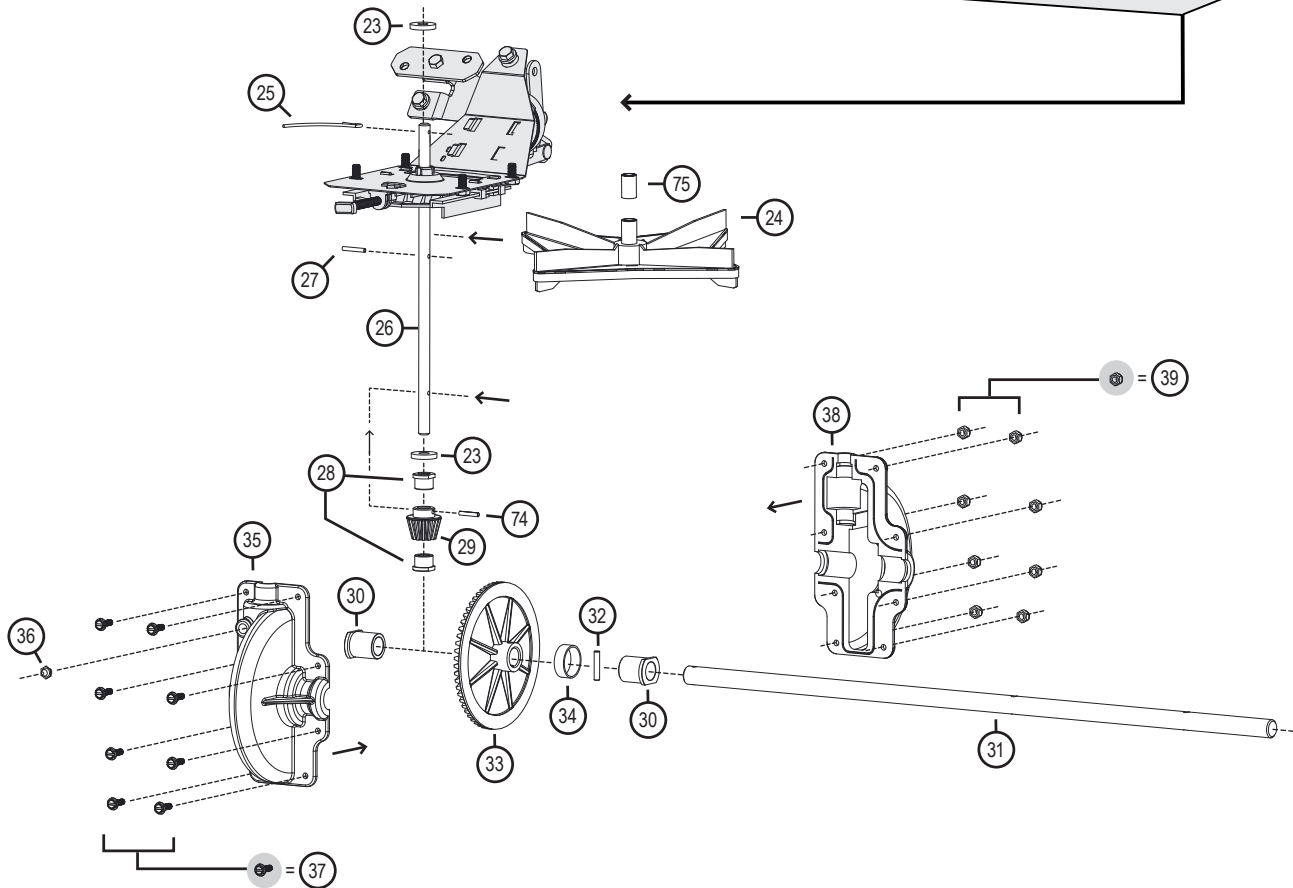
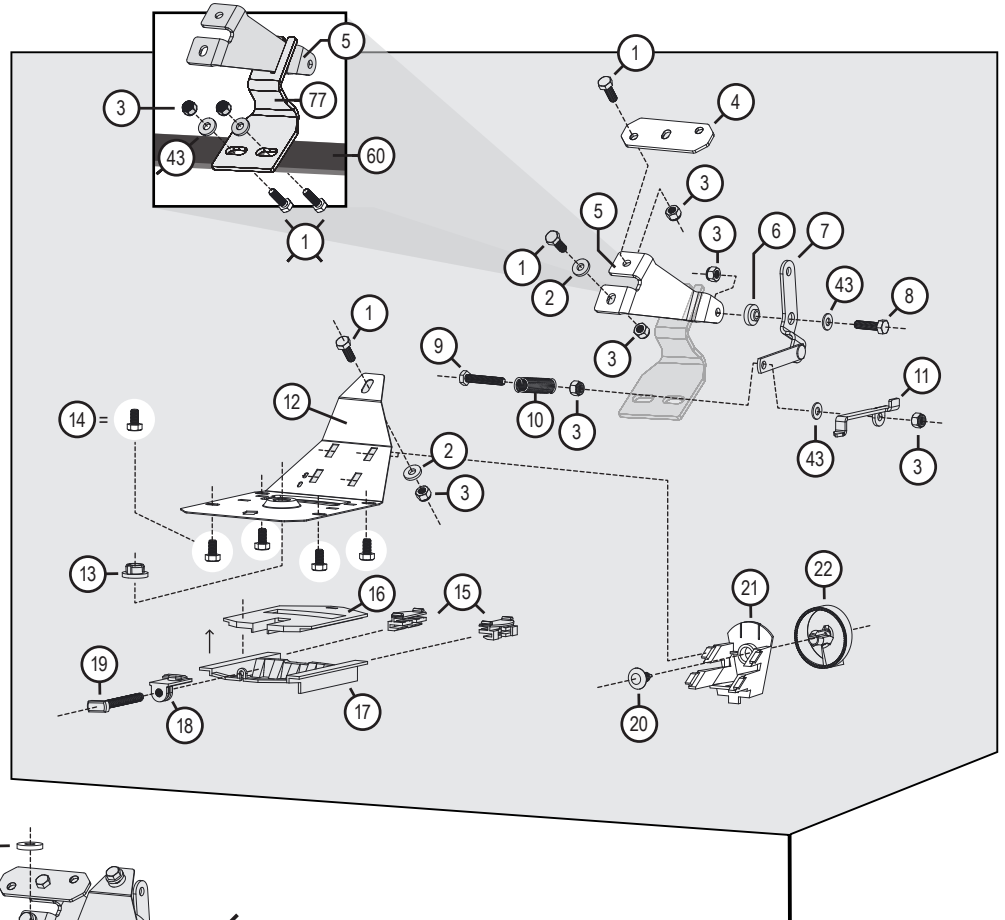
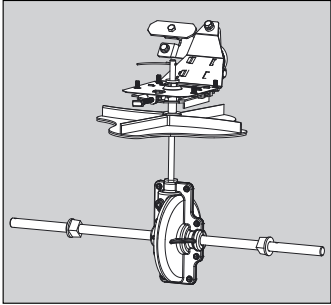

# Part Explosions

DO NOT RETURN PRODUCT IF YOU ARE MISSING PARTS. PLEASE CALL: 1 (800) 972-6130

## FRAME & HANDLE

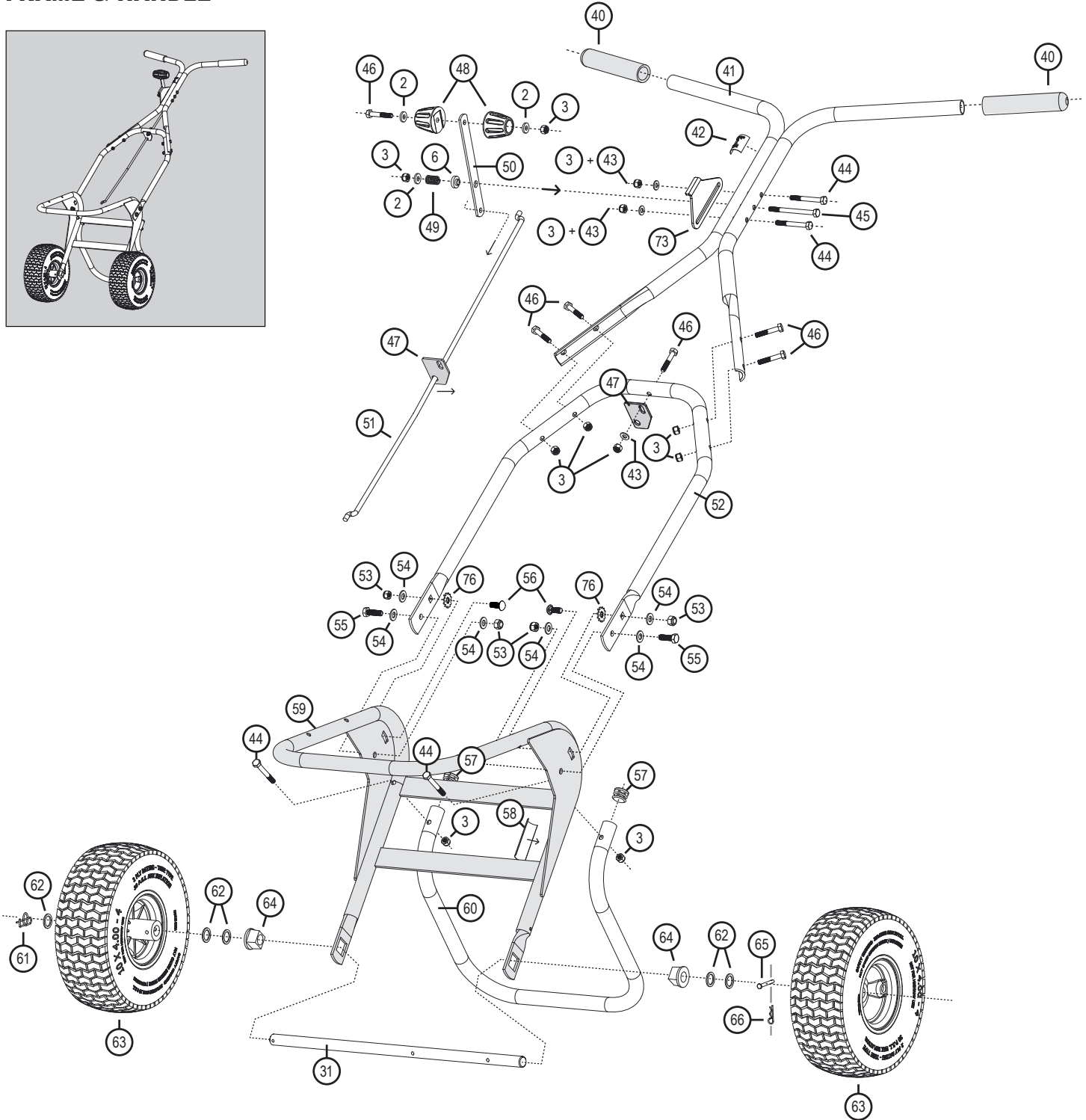

# Part Explosions

DO NOT RETURN PRODUCT IF YOU ARE MISSING PARTS. PLEASE CALL: 1 (800) 972-6130

## HOPPER

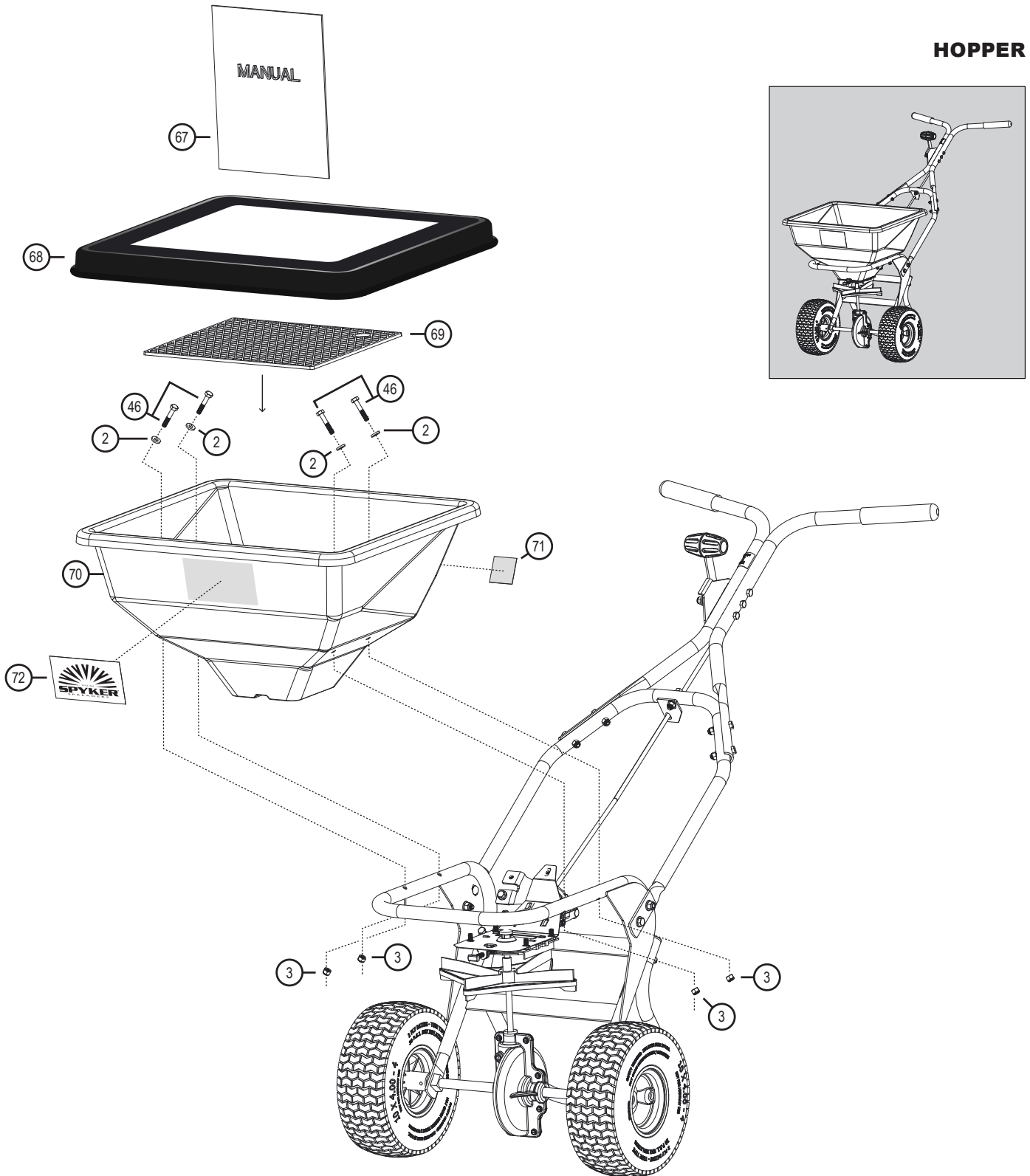

# ASSEMBLY

Remove the Part List (page 3) / Hardware Identifier (page 4) and set aside for frequent reference during assembly.

For reassurance, lay the nuts, bolts and washers down on page 4 to verify you're using the correct parts during assembly.



## Part List

DO NOT RETURN PRODUCT IF YOU ARE MISSING PARTS

No.	Part #	Qty	Description
1	1006084	5	Bolt, HexHd 1/4 x 3/4 SS
2	1001554	9	Washer, Nylon
3	1005198	23	Nut, NylonLock 1/4-20, SS
4	1017543	1	Plate, Linkage
5	1017501	1	Bracket, Linkage
6	1001533	2	Nylon Flange Bushing
7	1017340	1	Control Linkage Assembly
8	1001255	1	Screw 1/4-20 x 1" HexHd, SS
9	1017551	1	Bolt, HexHd 1/4-20 x 1.50
10	1017503	1	Spring, Gate
11	1008431	1	Rate Gate Link, Formed
12	1017580	1	Plate, Hopper Bottom
13	1008203	1	Hopper Bottom Bearing
14	1004880	4	Bolt, HexHd 1/4 x 1/2 SS
15	1001521	2	Guide, Rate Gate/Accessory
16	1001521	1	Rate Gate
17	1001523	1	Accoway Diffuser
18	1001525	1	Accoway Adj. Nut Bracket
19	1001528	1	Accoway Adjustment Screw
20	100215	1	Pine Tree Clip
21	1000211	1	Dial Mount
22	1000213	1	Dial, Plastic
23	1000198	2	Felt Washer
24	1000051	1	Spreading Spinner
25	1000223	1	Agitator Wire
26	1017420	1	Spinner Shaft, 50 Lb
27	1000054	1	Roll Pin 1/8 x 7/8
28	1001301	2	3/8 Spinner Shaft Bushing
29	1001518	1	Pinion Gear - Metal
30	1001299	2	Gearbox Bushing 5/8"
31	1017421	1	Axle, Wheel SS (SPY50-1P)
32	1018126	1	Axle, Wheel SS (SPY50L-1P)
33	1001304	1	Dowel Pin, 3/16 x 1, SS
34	1005389	1	Bevel Gear-metal
35	1005389	1	Nylon Spacer, Pin Retain
36	1005368	1	Gear Box Cover Front
37	1017710	1	Grease Zerk 1/4 Drive IN
38	1005337	8	Bolt, PhilHd 10-24 x 5/8" SS
39	1001308	1	Gear Box Cover Rear
40	1000225	2	Nut, NylonLock, #10-24 SS
			Handle Grip

©2017 Spyker Spreaders/A Brinly-Hardy Co.

Page 3

## Hardware Identifier

DO NOT RETURN PRODUCT IF YOU ARE MISSING PARTS. PLEASE CALL: 1 (800) 972-6130

ILLUSTRATIONS ON THIS PAGE ARE TO SCALE FOR FASTER IDENTIFICATION OF HARDWARE DURING ASSEMBLY.

- 1 Nut: Nylon Lock 1/4"-20 (x23) 1005198
- 2 Washer: Nylon (x10) 1001554
- 3 Nut: Nylon Lock, SS #10-24 (x8) 1001308
- 23 Washer: Felt (x2) 1000198
- 53 Nut: Nylon Lock 5/16"-18 (x4) 1001315
- 43 Washer: SS 1/4" (x7) 1001351
- 6 Flange Bushing Nylon (x2) 1001533
- 64 Washer: Flat SS 5/16" (x6) 45M1111SS
- 1 Bolt: Hex Head, SS 1/4 x 3/4" (x5) 1006084
- 62 Washer: Flat SS (x5) 1001350
- 9 Bolt: Hex Head 1/4-20 x 1.50 (x1) 1017551
- 79 Lock Washer: 5/16 Ext/Int Tooth (x2) 1017225
- 14 Bolt: Hex Head, SS 1/4 x 1/2" (x4) 1004880
- 44 Bolt: Hex Head, SS 1/4 x 2-1/4" (x4) 1007888
- 45 Bolt: Hex Head, SS 1/4 x 3-1/4" (x1) 1017371
- 46 Bolt: Hex Head, SS 1/4 x 1-1/2" (x10) 1001262
- 55 Bolt: Hex Head, SS 5/16-18 x 1" (x2) 1008811
- 63 Bolt: Carriage 5/16 x 3/4" (x2) 1017374

\*Exterior circumference of washers can vary. These dimensions are a measurement of the internal diameter of the washer.

1017628-C

Page 4

©2017 Spyker Spreaders/A Brinly-Hardy Co.

1017628-C

# Assembly

1. After removing all the parts from your box, place the pre-assembled hopper portion in your work area.

*Start upside down and facing this direction:*

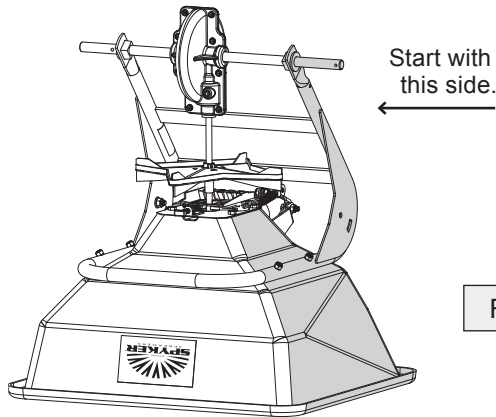

Fig. 1

2. Add 1 washer (62) to the wheel axle (31), then slide on the tire (63) and an additional washer (62).

Secure in place with the Rue Ring Locking Pin (61). (See figures 2b and 3c below).

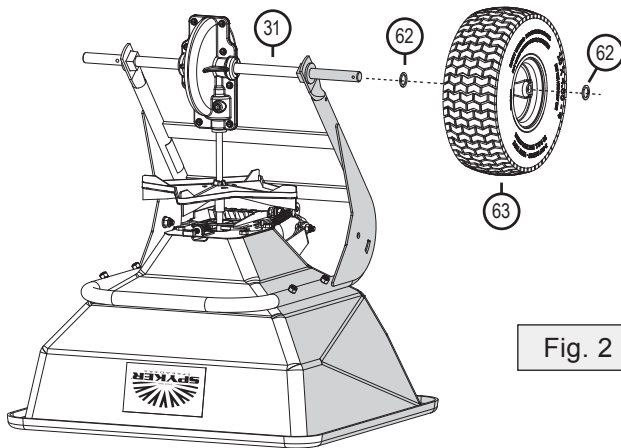

Fig. 2

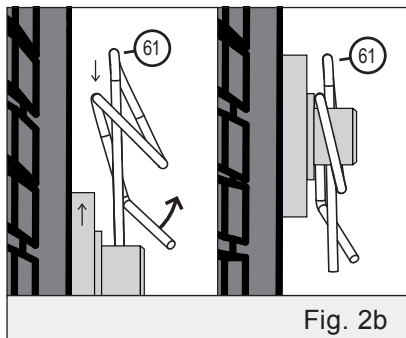

Fig. 2b

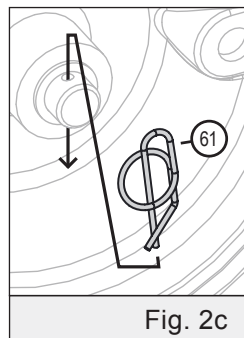

Fig. 2c

3. Add 2 washers (62) to the wheel axle (31). Slide on the tire (63).

*If last washer does not fit, remove tire & one of the interior washers.*

Lock the wheel in place with the Clevis Pin (65) and Hair Pin (66).

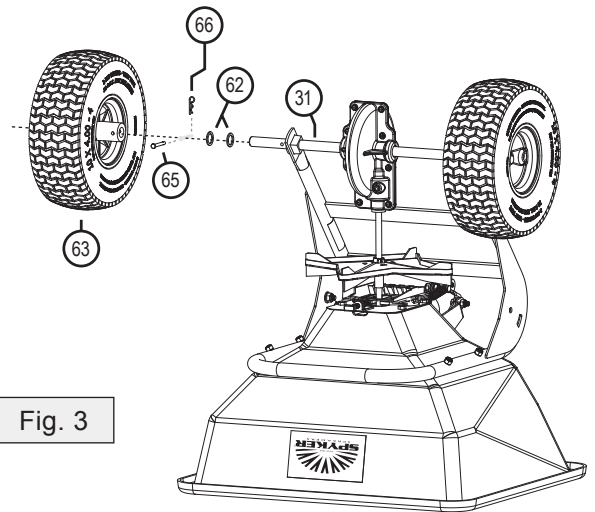

Fig. 3

4. Run two Hex Head bolts (44) through the frame (See Fig. 4 for alignment). Lower the tubing for the stand (59) on the bolts and secure in place with two Nylon Lock Nuts (3).

*Tighten completely with a 7/16" socket & wrench.*

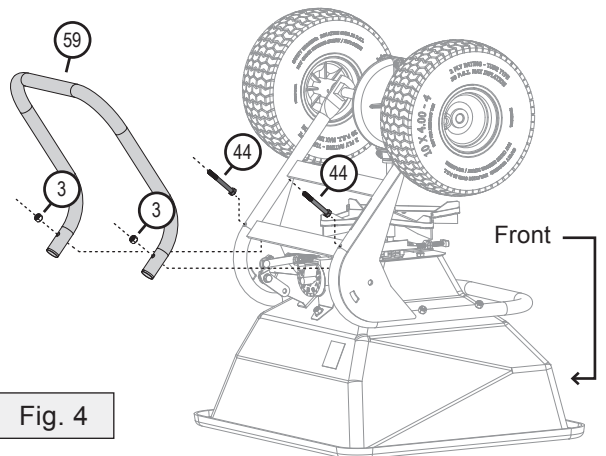
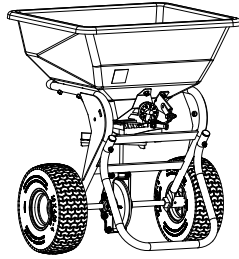

Fig. 4

# Assembly



- Align the two holes of the Lower Handle (52) with the two holes of the outer, rear edges of the Frame (59). Place one of the Lock Washers with teeth (76) between the square hole of the Handle (52) and the curved slot on the Frame (59).

Starting from the inside of the Frame, run a Carriage Bolt (56) through the curved slot of the Frame (59). The Carriage Bolt will also pass through the square hole of the Lower Handle (52) and the end will be facing out.

**Loosely** secure with a washer (54) and a Nylon Lock Nut (53). Use a 1/2" Socket & Wrench. Repeat on the other side.

**!** Do **NOT** tighten (yet).

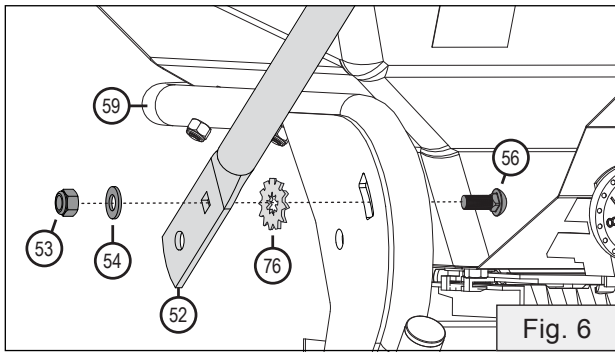

- Add one washer (54) to a hex head bolt (55). Starting from the outside edge, run the bolt through the circular holes of the Lower Handle (52) & Frame (59), then **loosely** secure with another washer (54) & a Nylon Lock Nut (53).

Use a 1/2" Socket & Wrench. Repeat on the other side.

**!** Do **NOT** tighten (yet).

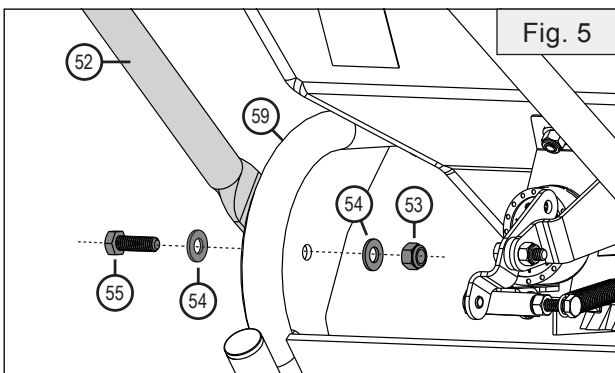

- Add the Handle Weldment (41) by lining it up on the Lower Handle tubing from step 6.

Secure the Handle in place by running four Hex Head Bolts (46) through the two handle ends from the outside. Tighten with four Nylon Lock Nuts (3) from the inside of the Lower handle (52).

Tighten with a 7/16" socket & wrench.

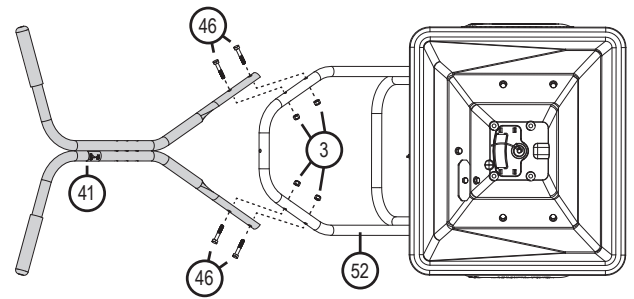

Fig. 8

- Setting the spreader handle height.**

Determine the angle / height you will want your handle. (At the highest point, the handle will be 36" off the ground. At the lowest point, the handle will be 32" off the ground).

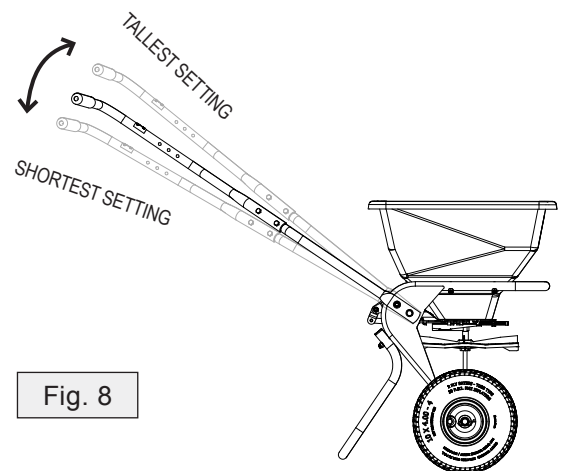

Fig. 8

**Tighten the hardware from steps 5 & 6 completely with a 1/2" socket & wrench.**



# Assembly

## 9. Adding the Control Lever Stop.

Orientation is very important on this step.

- The Control Lever Stop (73) needs to be centered over the three holes on the right side of the handle. (Same side as the On/Off sticker).

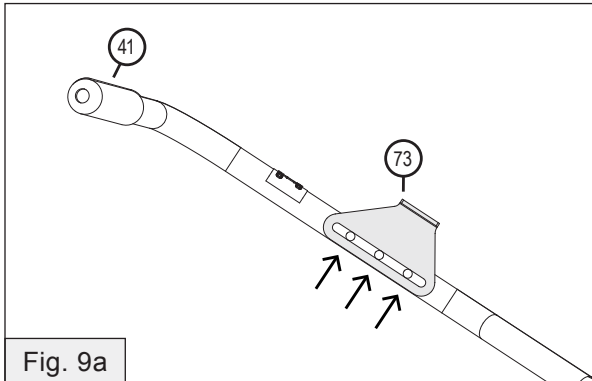

Fig. 9a

- The lip of the the Control Lever Stop (73) needs to be **POINTED OUT & AWAY** from the handle tubing. (See Fig 9b).

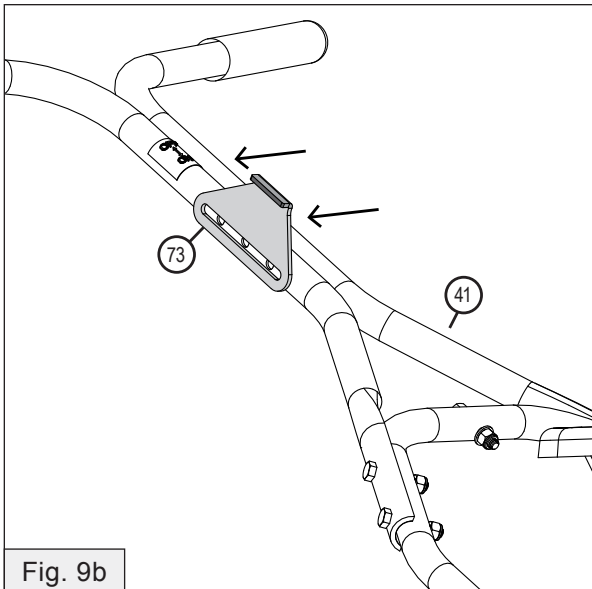

Fig. 9b

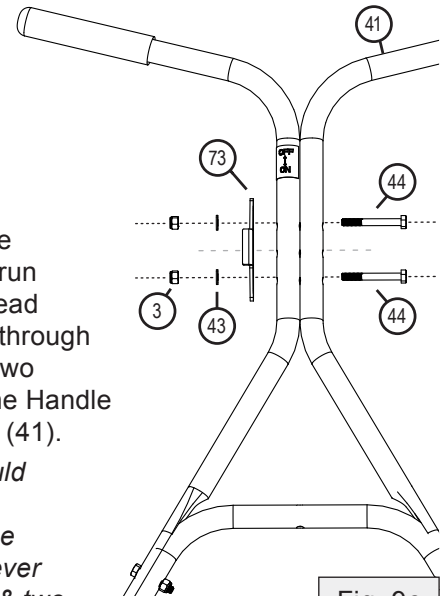

Fig. 9c

- Leave the center hole open and run two hex head bolts (44) through the outer two holes of the Handle Weldment (41).

*Bolts should also pass through the Control Lever Stop (73) & two 1/4" washers (43).*

- Add two Nylon Lock Nuts (3) on the ends of the Bolt (44). Verify the Control Lever Stop (73) is centered (see Fig 9a) before tightening the Nuts (3) completely, securing everything in place.

## 10. Adding the linkage bar.

Orientation is very important on this step.

The Linkage (51) is a long, thin bar that connects the dial and the Control Lever.

*Slide the Linkage (51) into the Linkage Assembly (7) from the side from left to right at a low angle, then lift it up toward the handle.*

(See Fig. 10b)

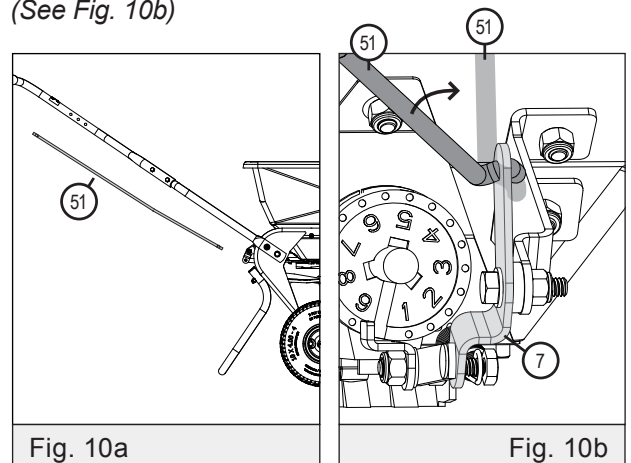

Fig. 10a

Fig. 10b

# Assembly

## 11. Adding the Linkage Guide Plate.

Orientation is very important on this step.

For this step, please follow the illustration notations below:

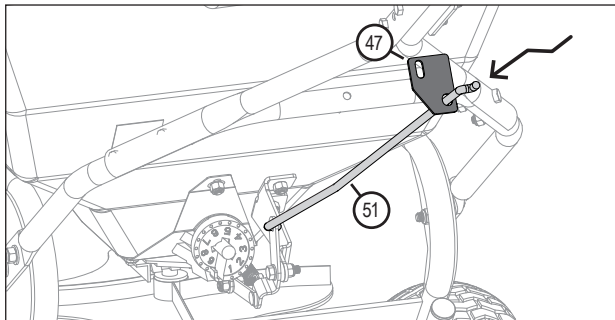

Fig. 11a Use the lower, circular hole of the Linkage Guide (47) and add it to the Linkage bar (51).

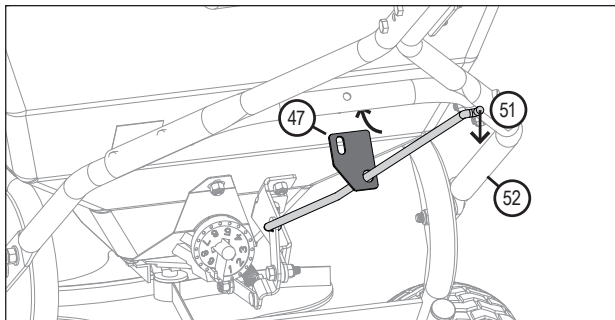

Fig. 11b Slightly lower linkage (51). Slide guide (47) down linkage & under the lower handle (52).

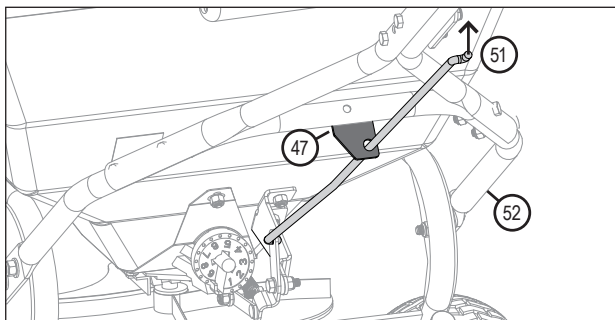
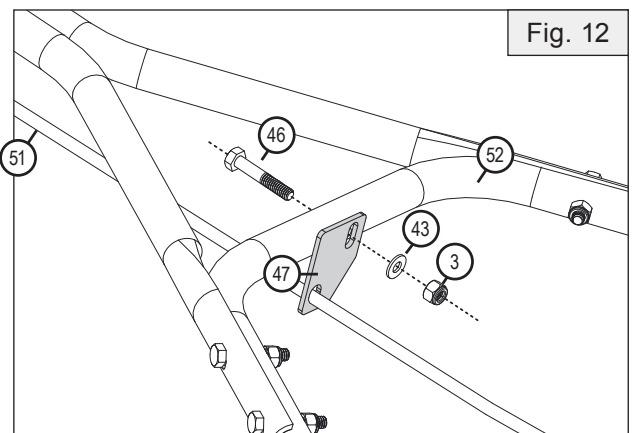

Fig. 11c Lift the linkage (51), aligning the top hole of the guide (47) with the hole of the lower handle (52).

## 12. Using Fig. 12 as a guide, insert a Hex Head Bolt (46) through the remaining hole at the top of the Lower Handle (52).

The bolt (46) should pass through the oval hole of the Linkage Guide (47) and a washer (43). Loosely secure in with a Nylon Lock Nut (3).

**!** Do **NOT** tighten (yet).



## 13. a) Adding the Control Lever

Start to slide a hex head bolt (45), through the remaining center hole on the handle.

*End of the bolt comes out through the side of the handle with the On/Off sticker and the Control Lever Stop (73) that was added on Step 9.*

Do **NOT** push the bolt 100% through (yet).

At a sideways angle, slide the bottom hole of the Control Lever onto the Linkage Bar (51).

See Fig. 13a

## b) Twist the Control Lever toward the hopper and then up, aligning the center hole of the Lever with the bolt (45) that was added in the last step.

Push the bolt (45) through the Control Lever.

See Fig. 13b



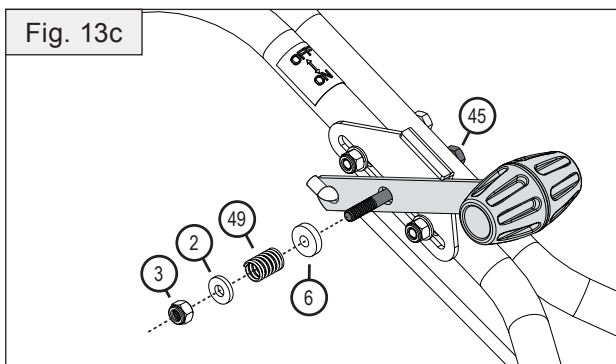
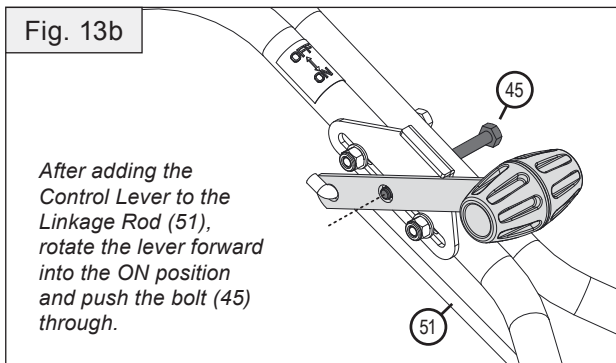
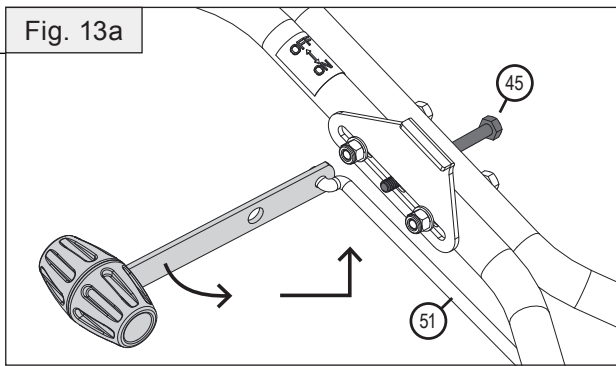

c) Add the Nylon Flange Bushing (6) to the bolt (45). \*Be sure to have the extended notch of the Flange facing the Lever.

Push the small extended notch of the Nylon Flange Bushing (6) into the center hole of the assembled Control Lever.

Add the Control Lever Spring (49) to the rest of the exposed bolt. **Loosely** keep parts in place with a Nylon Washer (2) & a Nylon Lock Nut (3).

**!** Do **NOT** tighten (yet).

#### 14. Checking the Rate Gate

Ensure the rate gate closes completely when the gate control lever is pulled back and locked into place.

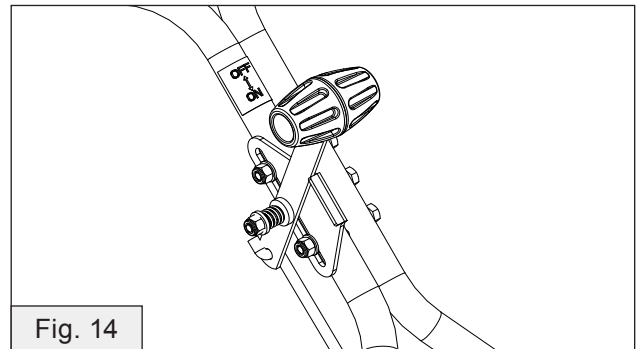

#### 15. Rate Gate Adjustment

*If the gate **IS** closed, skip to step 16.  
If it is **NOT** closed, follow these steps:*

- Ensure the hopper is empty.
- Turn the Spyker dial to #9. Remove the spring tension on the gate control lever by moving the lever to the Open position.

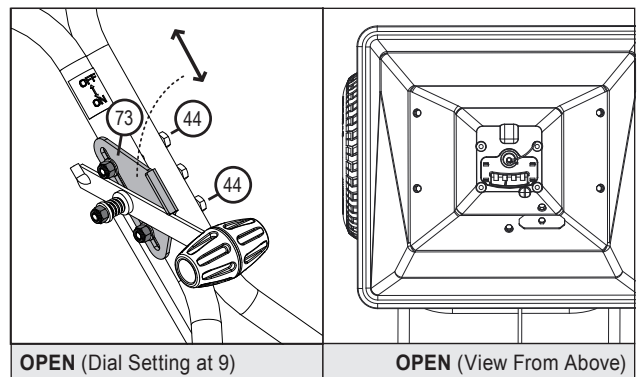

- Loosen the two bolts (44) that attach the Control Lever Stop (73).
- Slide the Control Lever Stop (73) forwards very slightly, then retighten bolts (44).

# Assembly

- e) Move the gate control lever to CLOSED and re-evaluate the rate gate. If it is closed, then no further adjustment is necessary.
- f) If the rate gate is still open, then repeat steps 3-5 until the gate is closed.

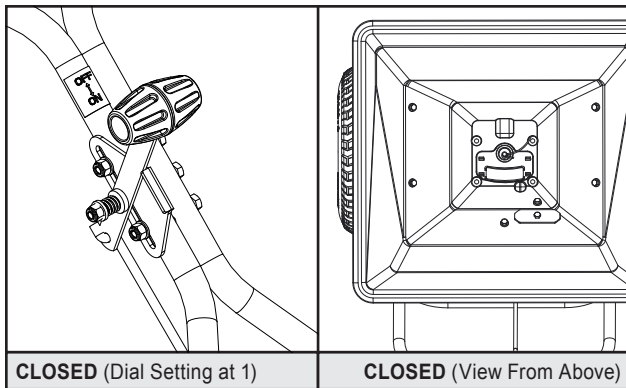

## 16. Tighten the Bolts

The center bolt that runs through the Control Lever needs to be tightened enough to keep the Lever secure, but also be free enough to function.

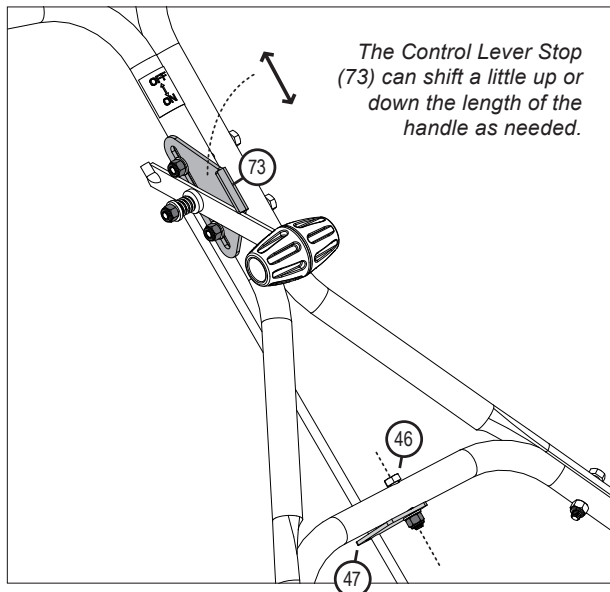

Secure the Linkage Guide (47) in place by tightening\* the bolt (46) that goes through the lower handle. (See step 12 on page 12 for clarification).

\*Bolt can remain slightly loose, allowing Linkage Guide to move.

## 17. Checking / Adjusting the Accuway

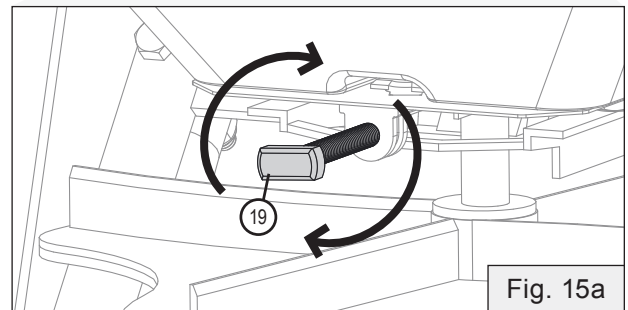
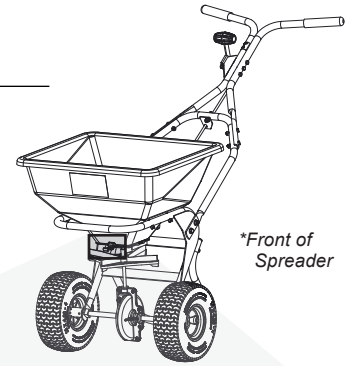

Start rotating the Accuway Adjustment Screw (19) clockwise.

Continue to rotate the ACCUWAY Adjustment Screw (19) clockwise (Fig. 15a) until the Accuway is out of view while looking down into the hopper (Fig. 15b).

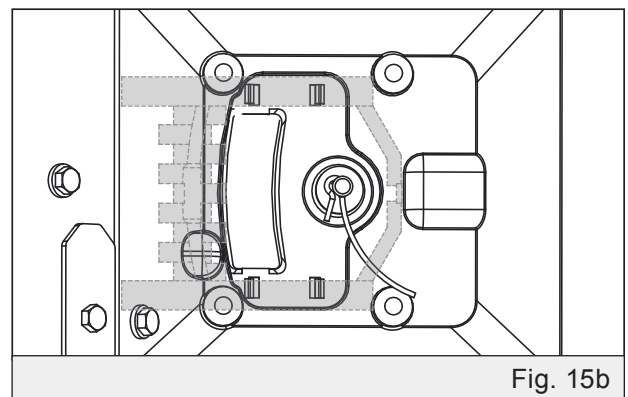

## 18. Final Step

Place the Screen (69) down inside the hopper.

Attach the Hopper Cover (68) by hooking it around the rim of the Hopper.

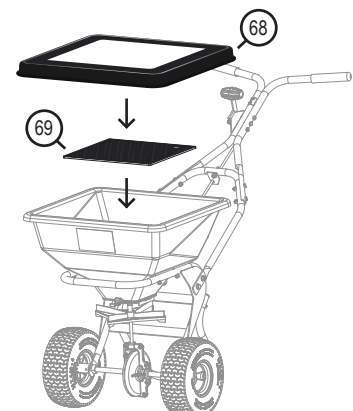

# Calibration

## **⚠ READ BEFORE USING**

**Spreader Calibration** - *Two items must be considered when calibrating a spreader:*

1. First, is the **DISTRIBUTION PATTERN** of the spreader. This is the pattern the product makes as it strikes the ground after being broadcasted from the spreader's spinner. There are many factors that affect the distribution pattern of a rotary spreader and some of them relate directly to the material. For this reason, it is recommended that the spreader be calibrated separately for every material.
2. Second, is the **PRODUCT APPLICATION RATE**. This is the amount of product applied per thousand square feet. This is important because over-application can be costly and may cause plant injury, while under application will reduce the effectiveness of the material.



### **WARNING: Avoid Injury!**

Chemicals can be dangerous. Avoid injury to operators or bystanders.

### **How to Test for a Uniform Distribution Pattern:**

1. Lay out shallow boxes or pans in a row on a line perpendicular to the spreader's travel direction. In the middle of the row, leave a gap wide enough for the spreader to be pushed through.

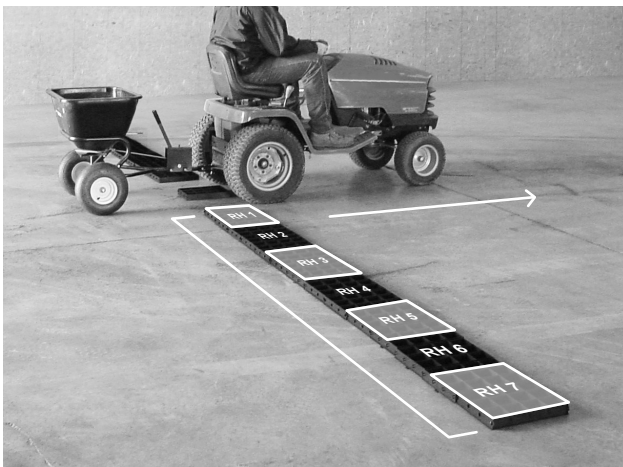

2. To conduct the test, begin with the Accuway completely rearward, and not in the way of the gate plate opening.

3. Set the Spyker dial to the correct dial position (see the dial settings chart on page 20).
4. Align the spreader approx. 20 feet in front of the gap in the row of pans.
5. Push the spreader approx. 3 mph, and open the gate lever approx. 15 feet before pans.
6. Push the spreader through the gap in the pans, then close the hopper lever about 5 feet past the pans.
7. Repeat steps 4-6 approx. 15 times or until enough material is in the pans so that it can be measured.
8. For each pan, record the distance from the end of the pan to the center line and weigh the material.



*Continues on page 14...*

**▲ READ BEFORE USING**

**How to Test for a Uniform Distribution Pattern:**

( ...continued from page 15).

CHART A																
PAN	LH PAN 7	LH PAN 6	LH PAN 5	LH PAN 4	LH PAN 3	LH PAN 2	LH PAN 1	CENTER PAN	RH PAN 1	RH PAN 2	RH PAN 3	RH PAN 4	RH PAN 5	RH PAN 6	RH PAN 7	
DISTANCE FROM CENTER																
WEIGHT OF MATERIAL																

9. Review the recorded weights. Ideally for an even distribution, LH Pan 1 and RH Pan 1 would have approximately the same material. The same for LH Pan 2 and RH Pan 2, etc.

10. If the spreader pattern is not even, then adjust the Accuway according to these charts and repeat steps 3-9.

*Please adjust in very small increments, as the Accuway is very sensitive.*

**Adjusting the Accuway**

NOTE: *Moving the Accuway plate will shift the material on the spinner. Adjustment is very sensitive & should be done in small increments until the spread pattern is centered.*

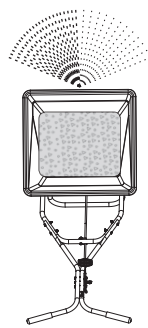
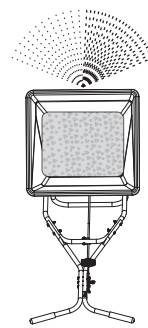
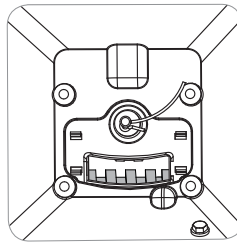
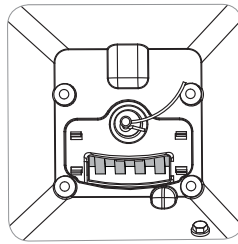
 Travel		
Spread Pattern	<b>HEAVY</b> to the Left	<b>HEAVY</b> to the Right
How to Adjust the Accuway Setting:	Turn dial & shift Accuway to the back half of the opening. (front) ↑  ↓ (handle)	Turn dial & shift Accuway to the front half of the opening. (front) ↑  ↓ (handle)

## READ BEFORE USING

### How to Set the Correct Product Application Rate (Spyker Dial Setting):

Complete "How to Test for a Uniform Distribution Pattern" (pages 15-16) to ensure distribution is even.

1. Once distribution is even, use the same data in Chart A (pg 16) to complete the steps below.

2. Find the pan on both the LH and RH side of the center that has approximately 50% of the amount of material as the center pan. Example:

- A. Center Pan has 0.25lb of material.
- B. Divide  $.25 \text{ lb} / 2 = 0.125 \text{ lb}$
- C. Find the LH and RH pan with approximately 0.125 lbs of material.

3. The effective pattern width is the distance from the LH pan to the RH pan found in step 2. To find the effective width, find the distance between the LH pan and RH pan.

- A. Example:  
LH Pan = 48" from center  
RH Pan = 48" from center  
Total Width = 96" (8 ft)

4. Find the linear distance needed to spread 1,000 sq. ft, taking into consideration the effective pattern width.

- A. Example:  
 $1,000 \text{ sq ft} / 8 \text{ ft (effective width)}$   
 $= 125 \text{ ft.}$
- B. Measure out a linear distance equal to 125 ft.

5. Weigh 20 lbs. of product and place it in the spreader hopper. Place Spyker Dial at #4 position. Spread material over the distance necessary to equal the linear distance found in step 4 (Ex. 125 ft.).

*While you are spreading, ensure you are traveling at a constant speed, usually 3 mph.*

6. Weigh the product left in the hopper and subtract this amount from the amount with which you started. The result is the application rate for this product in pounds per 1,000 sq. ft.

- A. Example:  
 $20 \text{ lbs} - 10 \text{ lbs (left over in hopper after spreading for 125 ft)}$   
 $= 10 \text{ lbs}$

7. Adjust the Spyker dial up or down as needed and repeat this procedure until the correct application rate is achieved.

**NOTE:** *Remember, speed is important, so ensure the speed you calibrate your spreader is the same speed that you travel during actual use.*

## Operation Instructions

### **⚠ WARNING: AVOID INJURY!**

Chemicals can be dangerous. Avoid injury to operators or bystanders

### **NOW YOU ARE READY TO PUT MATERIAL IN THE HOPPER**

- Make sure the rate gate is in the closed position.
- Read chemical container label for handling instructions. A Material Safety Data Sheet (MSDS) should be supplied by the chemical dealer and provides proper safety information.
- Wear proper clothing and safety equipment while handling or applying chemicals.
- Prohibit all smoking, drinking, and eating around chemicals.
- When spreading products containing herbicides, exercise extreme caution with respect to careless spreading and to wind-drift. Contact Of Some Products On Some Plants Can Be Fatal.
- Fill the spreader on a flat, level surface only. Fill on sidewalk, driveway, cardboard, etc. to avoid material loss.
- When filling hopper with material, always use screen to help break up clumps.

### **NOW YOU ARE READY TO SPREAD**

- Keep spinner blade clean. Excess material build-up can cause an uneven spread pattern.
- Keep the spinner blade level when spreading.
- DO NOT overload. Maximum capacity of this model is 50 lbs.
- DO NOT use on windy days.
- Spread header strips at the ends of the area OPPOSITE of the direction of spreading. This will provide a “turn-around” area, an area to re-align the spreader for the return spread.
- Example shown is for 6 ft. wide spread. Make the first spread pass at one-half the spread width from the edge of the spreading area or in this case, approximately 3 feet (or one big step).
- Additional spreading passes will be at the full spread width or approximately 6 ft. apart.
- TAKE A SIGHTING AT THE FAR END. Keep your eye on the sighting as you spread. You will not need to wonder where you are or where you have been. Continue until spreading is completed.
- Leftover fertilizer can be spread under trees and other high feeding areas without showing “edge of spread” lines.

*Tip: When not spreading (and if pushing the spreader some distance) tip the spreader so only the idle wheel is on the ground.*

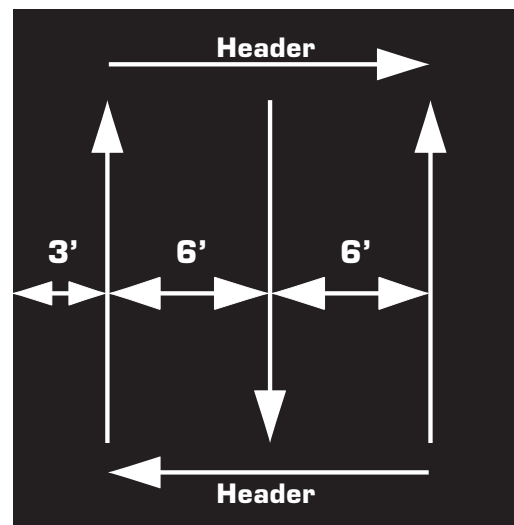



# Operation Instructions

## TIPS:

- Become familiar with the spreader before you put material in the hopper.
- Practice walking with the spreader, opening and closing the rate gate at the appropriate times.
- Travel at a constant speed and operate the spreader lever position. Remember: Open the rate gate after the spreader is in motion at operating speed (about 3 mph, or at a brisk walking pace).
- Close the rate gate while spreader is still at operational speed.
- The spread width ranges from 4 - 12 ft. wide depending on the density of the material and the operators walking speed.
- The spread thins or feathers at the outer edges, eliminating sharp, "Edge Of Spread" lines which cause stripes and streaks. Extra coverage can be given under trees and other heavy feeding areas without showing "Edge Of Spread" lines.

- Some products can be fatal to some plants
- Always remove material from hopper before attaching spreader on a vehicle-mounted spreader caddy.
- If a dial setting is not found, use the size and weight comparison table found in this manual. Determine a dial setting on the low side. If the setting proves to be too low, cover the area more than one time. A higher setting can be used when a proven dial setting is established.

*NOTE: Published dial settings are approximate only. The operation of the spreader, the condition of the material (damp or dry or over-pulverized) and weather conditions, are all contributing factors. For these reasons, it is often a good idea to spread the area 2 times - or one-half rate - in cross directions (SEE INFORMATION ON ONE-HALF RATE DIAL SETTINGS ON PAGES 20-21). **One-half rate dial settings are highly recommended under damp and humid conditions.***

## AFTER USE / CLEANING THE SPREADER:

### CLEAN AND OIL SPREADER IMMEDIATELY AFTER EACH USE

METHOD #1	METHOD #2
Wipe spreader thoroughly with an oily cloth. Oil all bearings and bearing areas.	Wash, rinse, and dry the spreader. <i>Note: Drying takes time. Moisture trapped in bearing areas is slow to go.</i> <b>Immediately after drying - oil all bearings and moving parts.</b> Make certain all operations are thorough.

*NOTE: Good "Dry Cleaning" (Method #1) is preferable to poor "Wet Cleaning" (Method #2).*

- It is virtually impossible to have rust and corrosion on a clean, dry, oiled surface.
- Again - just before using - oil all bearings & moving parts.
- In storage, ideally the spreader should be hung by the handle. In any case, do not pile weight on the spreader, as excess weight over a period of time can distort the tires.

### Oil Bearings and All Moving Parts

Make sure the spreader is running freely!

# Dial Settings

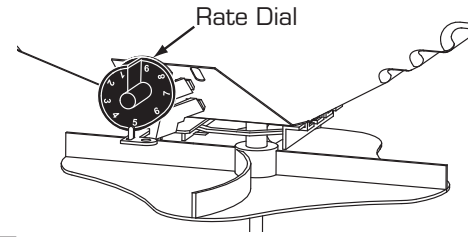

**NOTE: DIAL SETTINGS ARE APPROXIMATE ONLY!**

The settings shown in the charts below are for reference only. For initial settings that will result in true pounds per 1,000 sq ft, please return to "How to set the Correct Product Application Rate" on page 19.

The RATE DIAL has 9 numbers with 10 stops between each number. This allows for accurate control of the spreading rate. The dial is set with only a turn, it will automatically lock into the set position. LINE UP THE DIAL NUMBER WITH THE DIAL INDICATOR.

**WARNING:** When spreading products containing herbicides, exercise extreme caution with respect to careless spreading and to wind-drift.

Use the rotary agitator only if needed. Free-flowing, lump-free materials will not require the agitator. The rotary agitator is easily installed or removed. Note the clockwise rotation and sweep. Place felt washer around spinner shaft before inserting agitator.

PRODUCT	PARTICLE SIZE	Lbs. per 1000 sq. ft.	DIAL SETTINGS	
			Full Rate Once Over ↑ ↓	Half Rate Twice Over ↔
Fine Pellets		1	3.6	3.1
		2	4.0	3.5
		3	4.2	3.7
Mixed Fine Pellets		2	3.7	3.2
		4	4.7	4.1
		6	5.2	4.5
Small Pellets		2	3	2.2
		4	4.2	3.7
		6	4.5	4
Medium Nitrogen Pellets		1	3.5	3
		2	4.2	3.7
		3	4.7	4
Medium Pellets and Granuals		2	3.5	3
		4	4.2	3.8
		6	5.2	4.5
Large Heavy Pellets		2	3.8	3.3
		4	4.9	4.1
		6	5.9	4.9

RATE GATE DIAL SETTINGS	
LESCO SETTINGS	SPYKER SETTINGS
23	5.5
22	5.2
21	4.9
20	4.6
19	4.3
18	4.0
17	3.7
16	3.5
15	3.2
14	2.9
13	2.5
12	2.2
11	1.9
10	1.6
9	1.1



# Grass Seed Spreading Chart

## GRASS SEED SPREADING CHART

The settings shown in this chart are for reference only. For initial settings that will result in true pounds per 1,000 sq ft, please see the Operation Instructions on page 18.

Product	Bag Weight	Sq. Ft. Coverage	Dial Setting Full Rate	Dial Setting Half Rate	Spread Width
Blue Grass or Red Top	0.5 lbs	1,000	1.25	-	4
	1 lb	1,000	2.0	-	4
	2 lbs	1,000	2.5	-	4
Park, Merion, Delta or Kentucky Bluegrass	0.5 lbs	1,000	2.5	-	4
	1 lb	1,000	3.0	-	4
	2 lbs	1,000	3.5	-	4
Hulled Bermuda	2 lbs	1,000	2.75	2.25	6
	3 lbs	1,000	3.0	2.5	6
	4 lbs	1,000	3.25	2.75	6
Mixtures Including Coarse Seeds	2 lbs	1,000	6.0	-	6
	4 lbs	1,000	7.0	-	6
	6 lbs	1,000	7.0	-	6
Rye Grasses or Tall Fescue	2 lbs	1,000	6.0	-	6
	4 lbs	1,000	7.0	-	6
	6 lbs	1,000	7.75	-	6
Dichondra	4 oz.	1,000	1.9	-	8
	8 oz.	1,000	2.1	-	8
	12 oz.	1,000	2.5	-	8
Pensacola Bahia	4 lbs	1,000	4.5	3.75	7
	5 lbs	1,000	4.75	4.0	7
	6 lbs	1,000	5.0	4.25	7

## TROUBLESHOOTING / FREQUENTLY ASKED QUESTIONS

Problem	Diagnosis	Solution
Rate gate is binding and will not open/close properly.	Rate gate is jammed with debris.	<p>Thoroughly wash out hopper and shut off plates with water. Ensure debris is not stuck between shut off plate and rate gate plate.</p> <ul style="list-style-type: none"> <li>- <i>Very slightly loosen bolt 1017551 (9) allowing linkage 1017340 (7) to float.</i></li> <li>- <i>Very slightly loosen screw 1001255 (8) allowing linkage 1017340 (7) to float.</i></li> <li>- <i>Slide bracket 1017776 (76) to the left or right.</i></li> </ul>
There is not an even distribution coming from the spreader.	The Accuway is not set properly.	Reference the Accuway adjustment chart on page 16 of this manual.
Lever control is slow to open or there is a grinding noise.	Lever Control (53) is rubbing against the Control Lever Stop (73).	Loosen spring (49) by loosening locknut (3). <i>See fig 13C.</i>
Lever control is making a grinding noise.	Linkage (51) is rubbing against the Guide Plate (47).	Loosen guide plate (47) and adjust up/down.

Question	Solution
What is the difference between the Accuway and Rate Gate?	<p>The <b>Accuway Adjustment Screw</b> (19) is a small black screw with a rectangular head, located on the front of the Spreader. This screw controls the <u>direction</u> of the distribution. See page 16.</p> <p>The <b>Rate Gate Dial</b> (22) is a white circular knob on the back of the Spreader. This dial controls the <u>amount</u> of distribution. See page 20.</p>
How do I use the Accuway?	<p>For initial setup, please reference step 17 of the assembly (on page 14) and then calibrate your spreader. <i>See calibration steps: pages 15-17.</i></p> <p>To adjust your Accuway settings, refer to the chart on page 16.</p>

# Notes

---

---

---

---

---

---

---

---

---

---

---

---

---

---

---

---

---

---

---

---

---

---

---

---

---

---



## **WARRANTY**

### **1 YEAR LIMITED WARRANTY**

This is warranted to the original purchaser only. Spyker will replace parts with defects in materials and workmanship, for a period of one year from the date of purchase.

For Spyker Spreaders—a Brinly-Hardy Company, products employing metal gear systems, pinion and bevel, these metal gears, only, not inclusive of any other parts or materials, are warranted for the life of the spreader, not to be used for replacement or repair past original purchase.

Spyker Spreaders will not be liable for any loss, damage or expense including, but not limited to, consequential or incidental damages, arising from the operation, condition or use of the item. The sole and exclusive remedy against Spyker Spreaders being the replacement of the defective parts. This warranty gives you specific legal rights, and you may also have other rights which vary from state to state.

**This express warranty, which is applicable only to the original purchase, is in lieu of and excludes all other warranties, whether expressed or implied by operation of law or otherwise, including any warranty of merchantability or fitness for particular purpose.**

**SPYKER SPREADERS**  
Jeffersonville, IN 47130 USA  
Phone: 800.972.6130  
[www.spyker.com](http://www.spyker.com)