

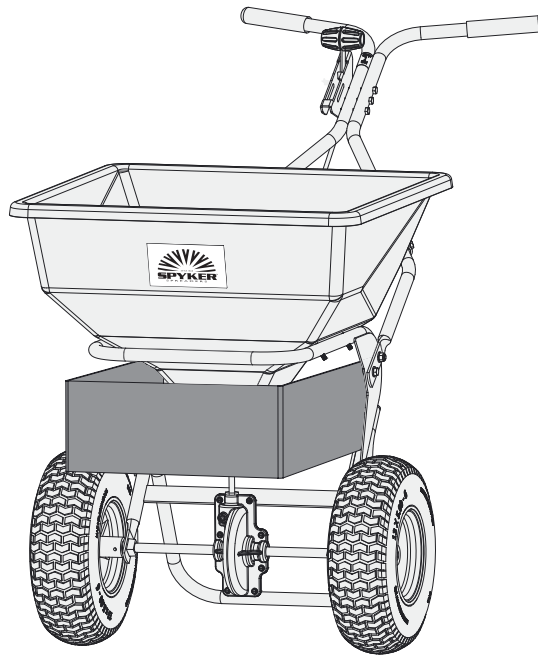

OPERATOR'S MANUAL

Model SPY100-1S Push Spreader



Spyker Spreaders

Contact us at 800.972.6130
www.spyker.com

▲ IMPORTANT

**This manual contains information for the safety of persons and property.
Read it carefully before assembly and operation of the equipment!**

TABLE OF CONTENTS

Safety 2
Part List 3
Hardware Identifier 4
Part Explosions 5-7

Assembly 8-13

Operation Instructions 14-15
Gauge Settings 15

Warranty 16

OPERATE SAFELY

Read Before Using:

- Keep bystanders away when you operate this machine.
- Use this machine for intended purpose only.
- Do not let children or an untrained person operate machine.
- Keep all parts in good condition and properly installed. Fix damaged parts immediately. Replace worn or broken parts.
- Do not modify the machine or safety devices. Unauthorized modifications to the machine may impair its function and safety, and void the warranty.
- Do not let anyone sit or ride on equipment during operation.
- Wear substantial footwear and long trousers. Do not operate the equipment when barefoot or wearing open sandals.
- Do not wear loose fitting clothing that can get caught in moving parts.
- Always wear eye protection when operating the equipment.
- Stay alert for holes in the terrain and other hidden hazards.
- Watch out for traffic when crossing or near roadways.
- Before you operate any feature of this machine, observe your surroundings and look for bystanders.
- Always wash hands after contact with fertilizers and pesticides.
- Keep all nuts, bolts and screws tight to be sure the equipment is in safe working condition.
- Always remove material from hopper before attaching spreader on a vehicle-mounted spreader caddy.

Part List

DO NOT RETURN PRODUCT IF YOU ARE MISSING PARTS. PLEASE CALL: 1 (800) 972-6130

No.	Part #	Qty	Description
1	1000198	2	Felt Washer
2	1017350	1	Hopper Bottom Plate
3	1000203	1	Hopper Bottom Bearing
4	1008244	1	Rate Gate
5	1001521	4	Guide, Rate Gate/Accuway
6	1005211	1	Spinner Plastic Lg Black
7	1008078	1	Axle, Spinner
8	1000054	1	Roll Pin 1/8 X 7/8
9	1006084	6	Bolt, HexHd 1/4x3/4 SS
10	1017543	2	Plate, Linkage
11	1005198	24	Nut, NylonLock 1/4-20, SS
12	1017541	1	Bracket, Linkage
13	1017542	1	Spring, linkage
14	1017364	1	Control Linkage
15	1001533	3	Nylon Flange Bushing
16	1001351	5	Washer, 1/4" SS
17	1001255	2	Screw 1/4-20 X 1"HexHd,SS
18	1008270	1	Linkage, Round
19	1017555	1	Nut, 5/16-18
20	1017554	1	Washer, Lock 5/16"
21	1017553	1	Bracket, Angle
22	1001315	5	Nut, Nylon Lock 5/16-18
23	1000844	1	Agitator Blade Weldment
24	1001273	1	Hairpin (299 Agitator) SS
25	1001301	2	3/8 Spinner Shaft Bushing
26	1001518	1	Pinion Gear - Metal
27	1000053	1	Roll Pin 1/8 X 3/4
28	1001299	2	Gearbox Bushing 5/8"
29	1001516	1	Bevel Gear-metal
30	1005389	1	Nylon Spacer, Pin Retain
31	1001304	1	Dowel Pin, 3/16 x 1, SS
32	1008085	1	Axle, Wheel
33	1005336	1	Gear Box Cover Front
34	1005337	1	Gear Box Cover Rear
35	1017710	8	Bolt, PhlpHd 10-24x5/8" SS
36	1005368	1	Grease Zerk 1/4 Drive IN
37	1001308	8	Nut, NylonLock, #10-24 SS
38	1000225	2	Handle Grip
39	1017620	1	Weldment, Handle
40	1001262	10	Bolt, HexHd 1/4x1-1/2 SS

No.	Part #	Qty	Description
41	1001554	11	Washer, Nylon
42	1007828	2	Knob, Handle
43	1017345	1	Lever, Control
44	1017346	1	Spring, Control Lever
45	1017626	3	Label, Reflective
46	1017552	1	Gauge, Winter
47	1000000	1	On-off Decal
48	1007888	4	Bolt, Hex Head 1/4x2-1/4 SS
49	1017371	1	Bolt, Hex Head, 1/4x3-1/4 SS
50	1017544	1	Rod, Linkage
51	1017624	1	Plate, Guide
52	1017618	1	Handle, Lower
53	45M1111SS	6	Washer, Flat, SS-5/16"
54	1008811	2	Bolt, Hex 5/16-18x1 SS316
55	1017374	2	Bolt, Carriage, 5/16x3/4
56	1017504	2	Cap, Plastic
57	L-1744-6	1	Label, Serial#, Spyker
58	1017328	1	Large Frame Weldment, SS
59	1005414	1	Rue Ring Locking Pin
60	1001350	5	Washer, Flat SS
61	F-283	2	Bearing, Axle
62	1017329	1	Stand, Large Frame (SS)
63	1001274	1	Clevis Pin, 3/16x1-3/4
64	1005367	1	Hair Pin, SS Pivot Mount
65	1001607	2	Wheel, 12" Drive/Idle
66	1017630	1	Manual
67	1017579	1	Cover, Hopper 100#
68	1017547	1	Screen, 100#
69	1017540	1	Hopper
70	1017709	1	Decal Spyker Ice
71	1017725	2	Lock Washer Ext/Int Tooth 5/16
72	1017722	1	Bolt, Carriage 6mm x 40mm
73	1017723	1	Spacer, Plastic
74	1017724	1	Washer, External Tooth M6
75	1007575	3	Knob, Deflector
76	1017731	1	Deflector
77	1017637	2	Bolt, Carriage 6mm x 20mm



Hardware Identifier



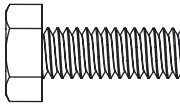
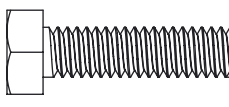
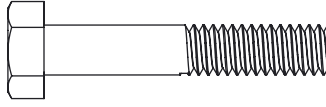

ILLUSTRATIONS ON THIS PAGE ARE TO SCALE FOR FASTER IDENTIFICATION OF HARDWARE DURING ASSEMBLY.

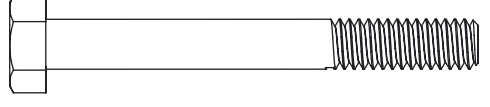
DO NOT RETURN PRODUCT IF YOU ARE MISSING PARTS. PLEASE CALL: 1 (800) 972-6130

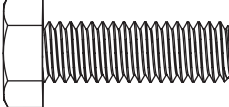
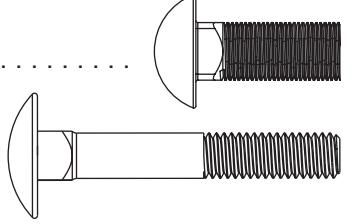
- 11 Nut: Nylon Lock: 1/4"-20 (x24)  **1005198**
- 19 Nut: 5/16"-18 (x1)  **1017555**
- 22 Nut: Nylon Lock: 5/16"-18 (x4)  **1001315**
- 37 Nut: Nylon Lock, SS: #10-24 (x8) ...  **1001308**
- 15 Flange Bushing Nylon (x3)  **1001533**

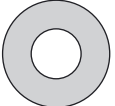
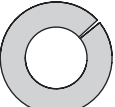
- 9 Bolt: Hex Head, SS 1/4 x 3/4" (x3)  **1006084**
- 17 Screw: Hex Head, SS 1/4-20 (x1)  **1001255**
- 40 Bolt: Hex Head, SS: 1/4 x 1-1/2" (x10)  **1001262**

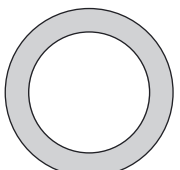
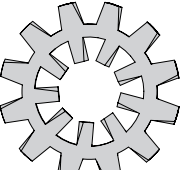
- 48 Bolt: Hex Head, SS: 1/4 x 2-1/4" (x4)  **1007888**
- 49 Bolt: Hex Head, SS: 1/4 x 3-1/4" (x1)  **1017371**
- 54 Bolt: Hex Head, SS 5/16-18 x 1" (x2)  **1008811**
- 72 Bolt: Carriage: 6mm x 40mm (x1)  **1017722**

- 1 Washer: Felt (x2)  **1000198**
- 16 Washer SS 1/4" (x5)  **1001351**
- 20 Washer: Lock 5/16" (x1)  **1017554**
- 41 Washer Nylon (x10)  **1001554**
- 53 Washer: Flat SS 5/16" (x6)  **45M1111SS**
- 60 Washer: Flat SS (x5)  **1001350**
- 70 Lock Washer: 5/16 Ext/Int Tooth (x2)  **1017225**
- 74 Washer: External Tooth M6 (x1)  **1017724**

 *Exterior circumference of washers can vary. These dimensions are a measurement of the internal diameter of the washer.

Part Explosions

DO NOT RETURN PRODUCT IF YOU ARE MISSING PARTS. PLEASE CALL: 1 (800) 972-6130

RATE GATE + AXLE / SPINNER

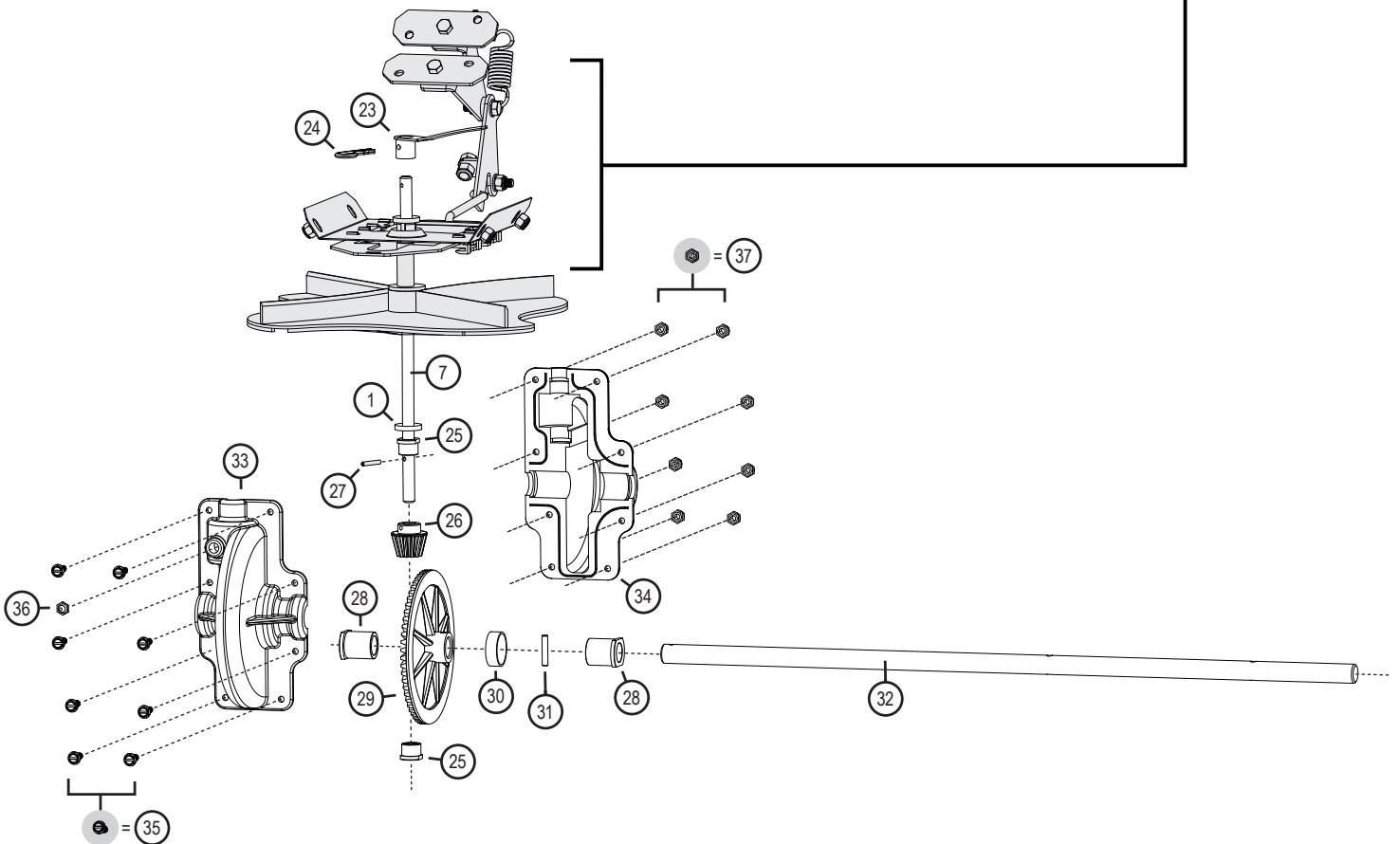
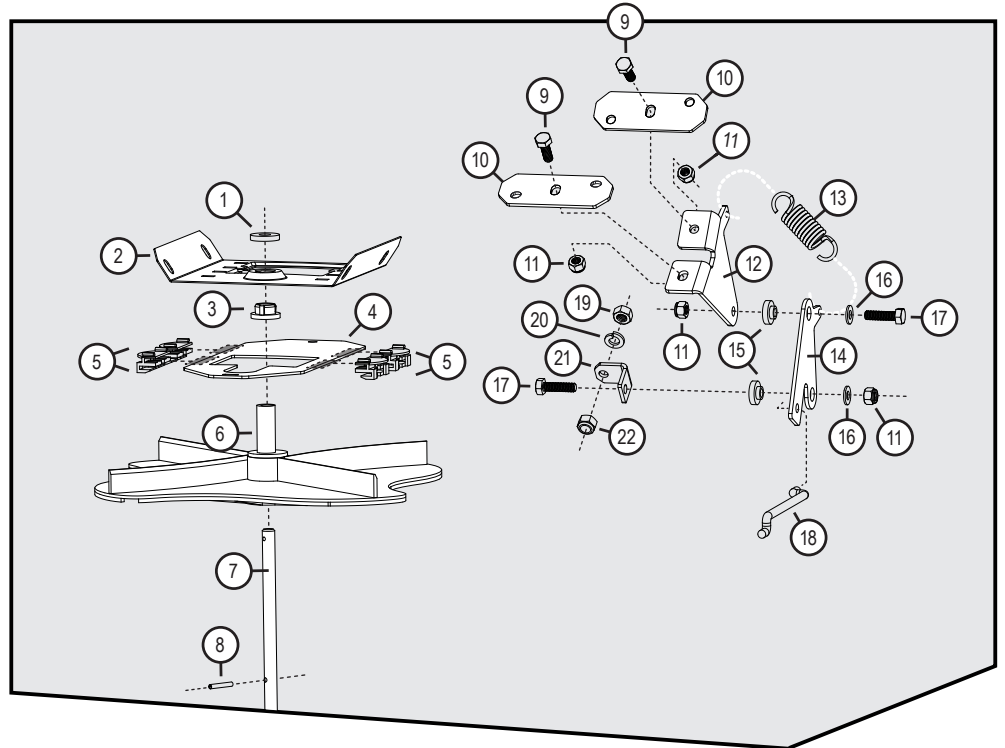
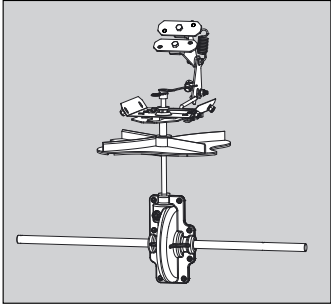

Part Explosions

DO NOT RETURN PRODUCT IF YOU ARE MISSING PARTS. PLEASE CALL: 1 (800) 972-6130

FRAME & HANDLE

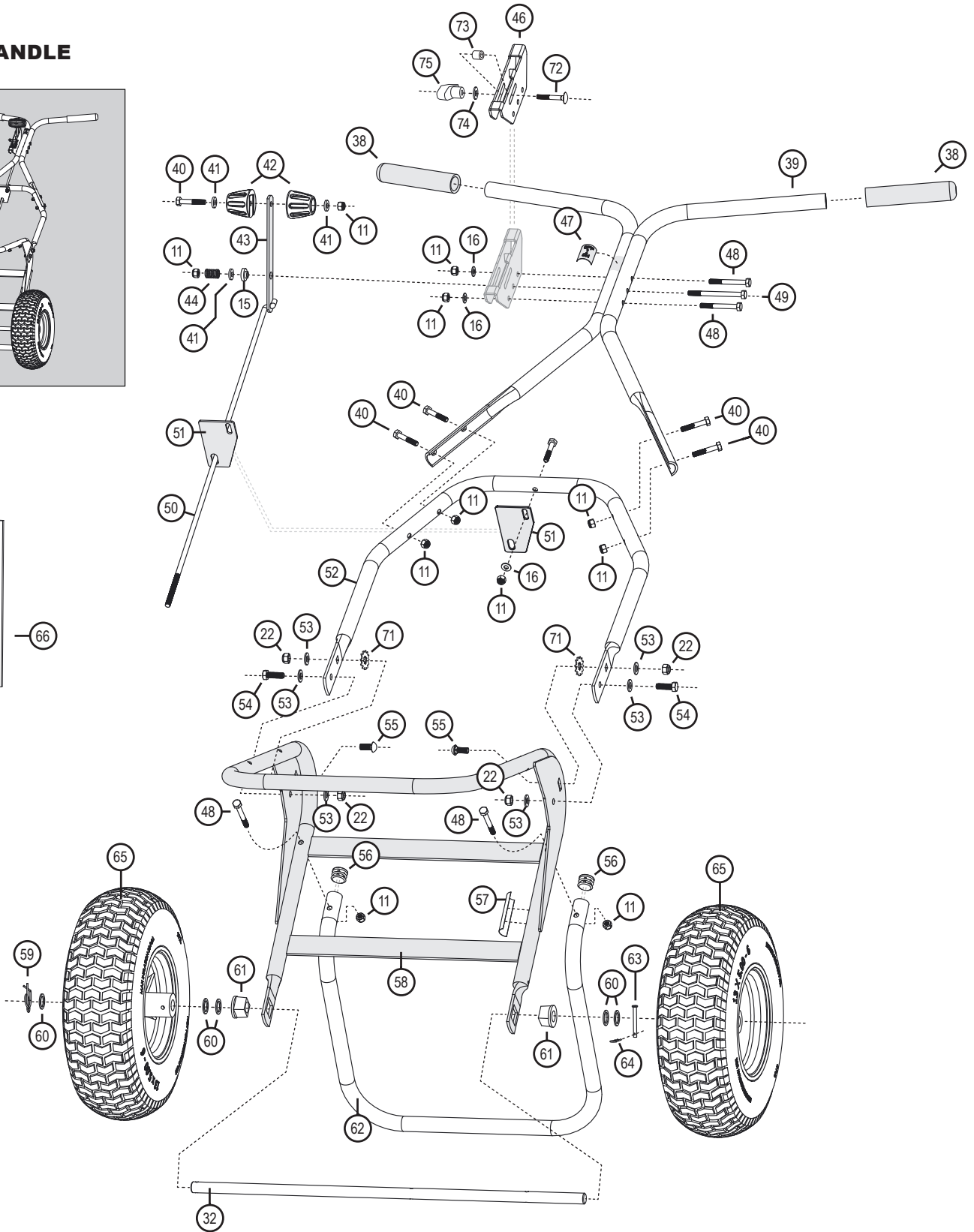
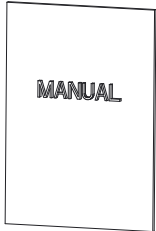
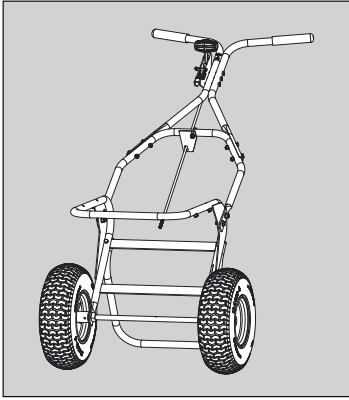

Part Explosions

DO NOT RETURN PRODUCT IF YOU ARE MISSING PARTS. PLEASE CALL: 1 (800) 972-6130

HOPPER

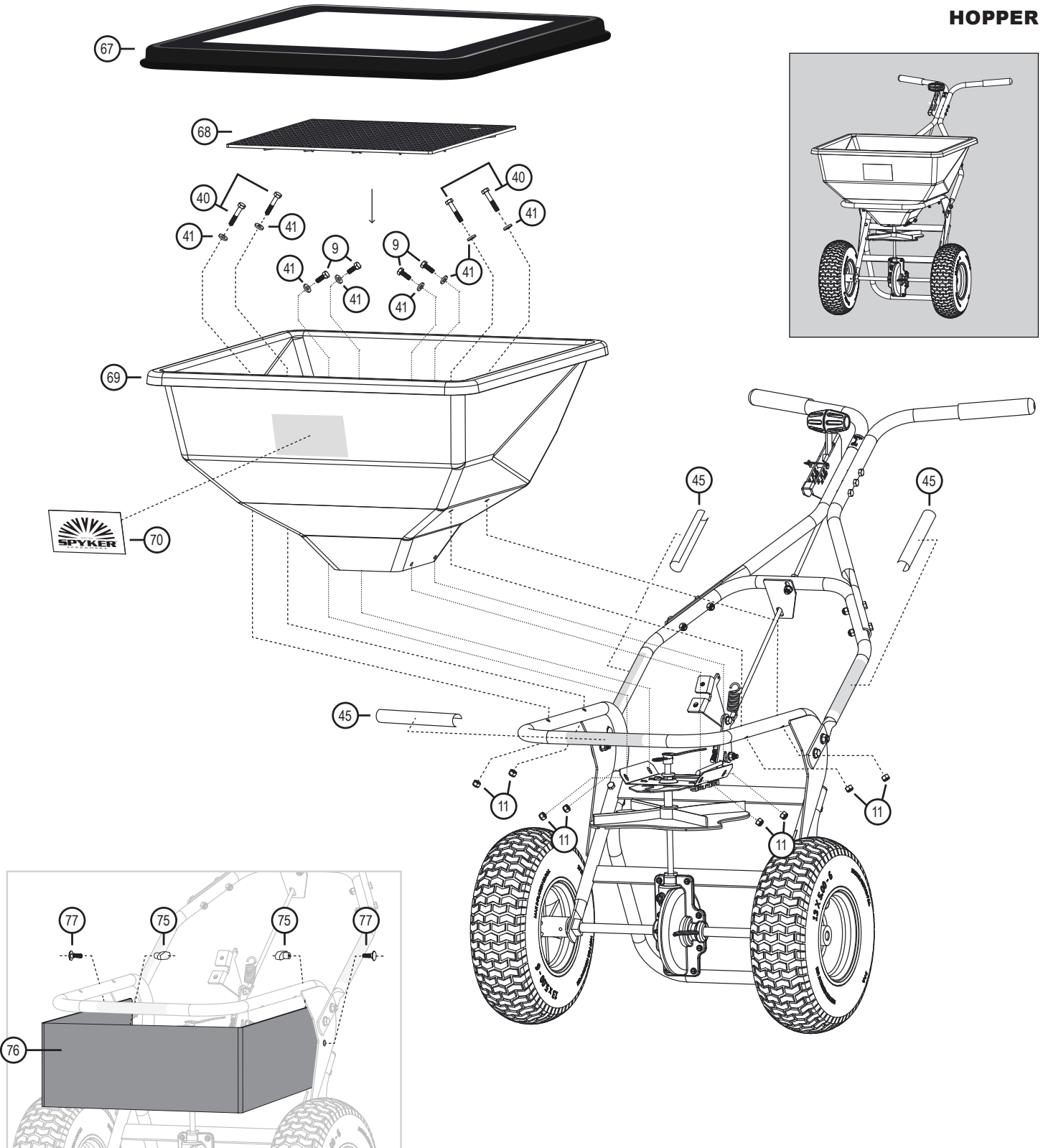

ASSEMBLY

Remove the Part List (page 3) / Hardware Identifier (page 4) and set aside for frequent reference during assembly.

For reassurance, lay the nuts, bolts and washers down on page 4 to verify you're using the correct parts during assembly.



Part List

No.	Part #	Qty	Description
1	1000198	2	Felt Washer
2	1017350	1	Hopper Bottom Plate
3	1000203	1	Hopper Bottom Bearing
4	1008244	1	Rate Gate
5	1001521	4	Guide, Rate Gate/Accuway
6	1005211	1	Spinner Plastic Lg Black
7	1008078	1	Axle, Spinner
8	1000054	1	Roll Pin 1/8 X 7/8
9	1005084	6	Bolt, HexHd 1/4x3/4 SS
10	1017543	2	Plate, Linkage
11	1005198	24	Nut, NylonLock 1/4-20, SS
12	1017541	1	Bracket, Linkage
13	1017542	1	Spring, Linkage
14	1017364	1	Control Linkage
15	1001533	3	Nylon Flange Bushing
16	1001351	5	Washer, 1/4" SS
17	1001255	2	Screw 1/4-20 X 1" HexHd SS
18	1008270	1	Linkage, Round
19	1017555	1	Nut, 5/16-18
20	1017554	1	Washer, Lock 5/16"
21	1017553	1	Bracket, Angle
22	1001315	5	Nut, Nylon Lock 5/16-18
23	1000844	1	Agitator Blade Weldment
24	1001273	1	Hairpin (29g Agitator) SS
25	1001301	2	3/8 Spinner Shaft Bushing
26	1001518	1	Pinion Gear - Metal
27	1000053	1	Roll Pin 1/8 X 3/4
28	1001299	2	Gearbox Bushing 5/8"
29	1001516	1	Bevel Gear-metal
30	1005389	1	Nylon Spacer, Pin Retain
31	1001304	1	Dowel Pin, 3/16 x 1, SS
32	1008085	1	Axle, Wheel
33	1005336	1	Gear Box Cover Front
34	1005337	1	Gear Box Cover Rear
35	1017710	8	Bolt, PhlHd 10-24x5/8" SS
36	1005368	1	Grease Zerk 1/4 Drive IN
37	1001308	2	Nut, NylonLock, #10-24 SS
38	1000225	1	Handle Grip
39	1017620	1	Weldment, Handle
40	1001262	10	Bolt, HexHd 1/4x1-1/2 SS

©2017 Spyker Spreaders/A Brinly-Hardy Co.

Page 3

Hardware Identifier

ILLUSTRATIONS ON THIS PAGE ARE TO SCALE FOR FASTER IDENTIFICATION OF HARDWARE DURING ASSEMBLY.
DO NOT RETURN PRODUCT IF YOU ARE MISSING PARTS. PLEASE CALL: 1 (800) 972-6130

- 11 Nut: Nylon Lock: 1/4"-20 (x24) 1005198
- 19 Nut: 5/16"-18 (x1) 1017555
- 22 Nut: Nylon Lock: 5/16"-18 (x4) 1001315
- 27 Nut: Nylon Lock, SS: #10-24 (x8) 1001308
- 15 Flange Bushing Nylon (x3) 1001533
- 1 Washer: Felt (x2) 1000198
- 16 Washer SS 1/4" (x5) 1001351
- 20 Washer: Lock 5/16" (x1) 1017554
- 41 Washer: Nylon (x10) 1001554
- 53 Washer: Flat SS 5/16" (x6) 45M1111SS
- 60 Washer: Flat SS (x5) 1001350
- 70 Lock Washer: 5/16 Ext/Int Tooth (x2) 1017225
- 74 Washer: External Tooth M6 (x1) 1017724
- 9 Bolt: Hex Head, SS 1/4 x 3/4" (x3) 1006084
- 17 Screw: Hex Head, SS 1/4-20 (x1) 1001255
- 40 Bolt: Hex Head, SS: 1/4 x 1-1/2" (x10) 1001262
- 48 Bolt: Hex Head, SS: 1/4 x 2-1/4" (x4) 1007888
- 49 Bolt: Hex Head, SS: 1/4 x 3-1/4" (x1) 1017371
- 54 Bolt: Hex Head, SS 5/16-18 x 1" (x2) 1008811
- 72 Bolt: Carriage 6mm x 40mm (x1) 1017722
- 55 Bolt: Carriage 5/16 x 3/4" (x2) 1017374

©2017 Spyker Spreaders/A Brinly-Hardy Co.

Page 4

Assembly

1. After removing all the parts from your box, place the pre-assembled hopper portion in your work area.

Start upside down and facing this direction:

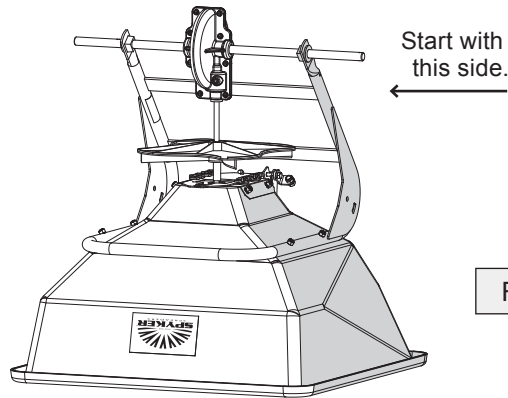

Fig. 1

2. Add 1 washer (60) to the wheel axle (32), then slide on the tire (65) and another washer (60).

Secure in place with the Rue Ring Locking Pin (59). (See figures 2b and 3c below).

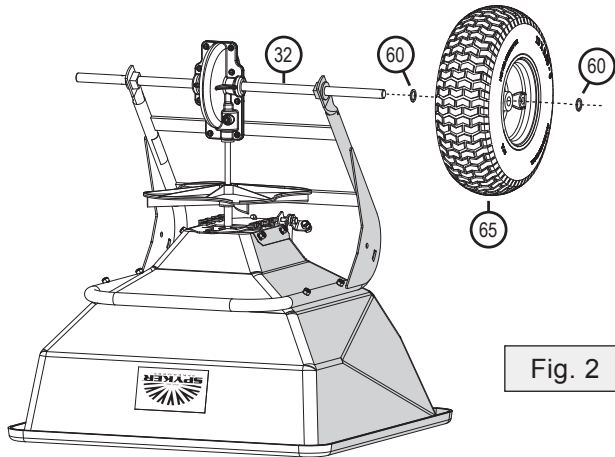

Fig. 2

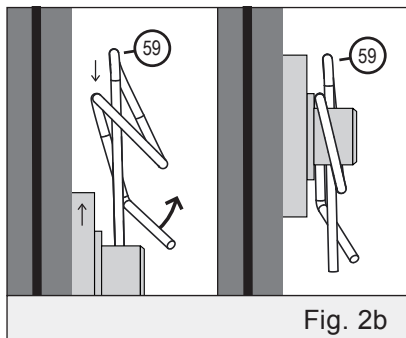

Fig. 2b

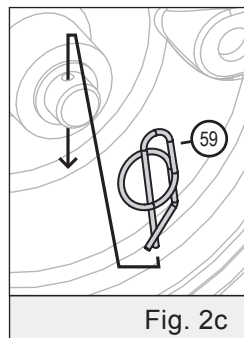

Fig. 2c

3. Add 2 washers (60) to the wheel axle (32). Slide on the tire (65).

If last washer does not fit, remove tire & one of the interior washers.

Lock the wheel in place with the Clevis Pin (63) and Hair Pin (64).

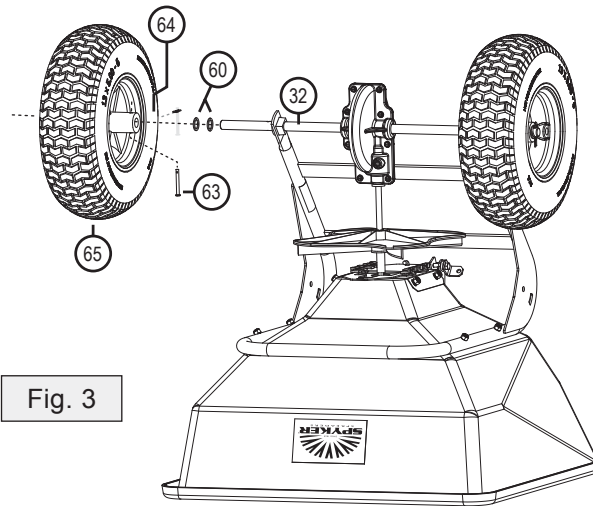

Fig. 3

4. Run two Hex Head bolts (48) through the frame (See Fig. 4 for alignment). Lower the tubing for the stand (62) on the bolts and secure in place with two Nylon Lock Nuts (11).

Tighten completely with a 7/16" socket & wrench.

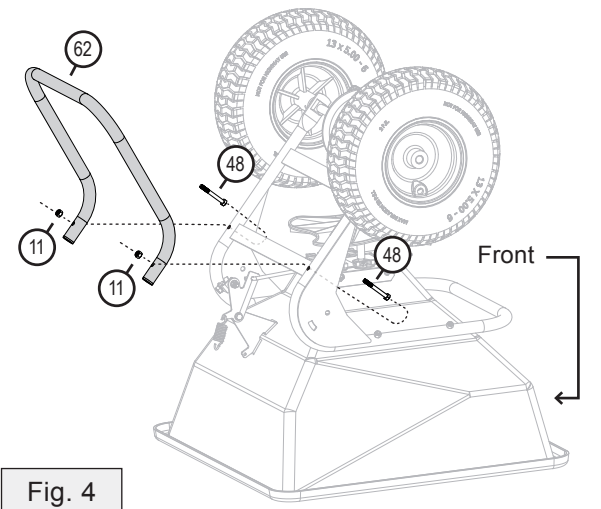
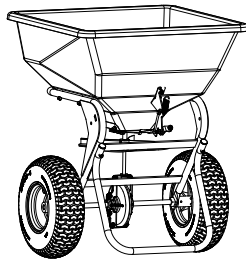

Fig. 4

Assembly



- Align the two holes of the Lower Handle (52) with the two holes of the outer, rear edges of the Frame (58). Place one of the Lock Washers with teeth (71) between the square hole of the Handle (52) and the curved slot on the Frame (58).

Starting from the inside of the Frame, run a Carriage Bolt (55) through the curved slot of the Frame (58). The Carriage Bolt will also pass through the square hole of the Lower Handle (52) and the end will be facing out.

Loosely secure with a washer (53) and a Nylon Lock Nut (52). Use a 1/2" Socket & Wrench. Repeat on the other side.

! Do **NOT** tighten (yet).

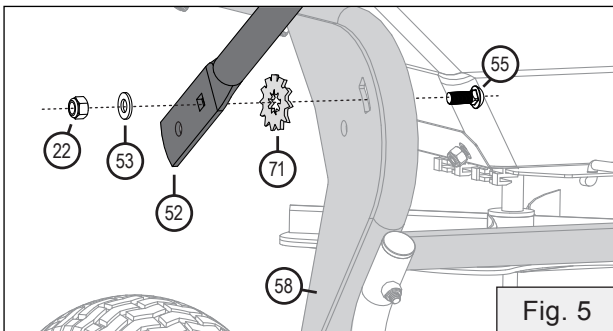

Fig. 5

- Add one washer (53) to a hex head bolt (54). Starting from the outside edge, run the bolt through the circular holes of the Lower Handle (52) & Frame (58). **Loosely** secure the bolt with a washer (53) & a Nylon Lock Nut (22).

Use a 1/2" Socket & Wrench. Repeat on the other side.

! Do **NOT** tighten (yet).

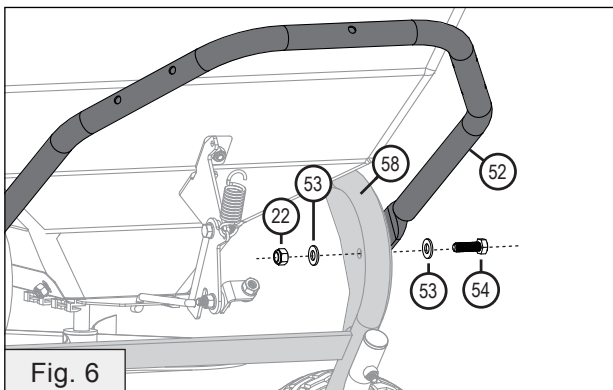

Fig. 6

- Add the Handle Weldment (39) by lining it up on the Lower Handle tubing from step 6.

Secure the Handle in place by running four Hex Head Bolts (40) through the two handle ends from the outside. Tighten with four Nylon Lock Nuts (11) from the inside of the Lower handle (52).

Tighten with a 7/16" socket & wrench.

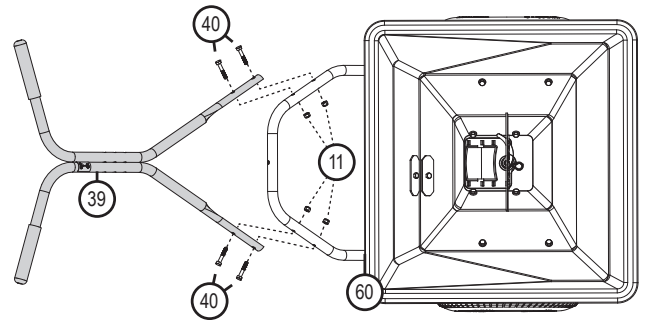

Fig. 7

- Setting the spreader handle height.**

Determine the angle / height you will want your handle. (At the highest point, the handle will be 37" off the ground. At the lowest point, the handle will be 32" off the ground).

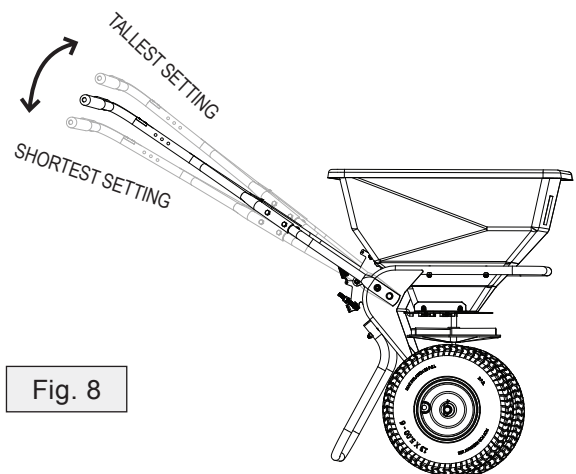

Fig. 8

Tighten the hardware from steps 5 & 6 completely with a 1/2" socket & wrench.

Assembly

9. Adding the Winter Gauge.

Orientation is very important on this step.

- The Winter Gauge (46) needs to be centered over the three holes on the right side of the handle. (Same side as the On/Off sticker).

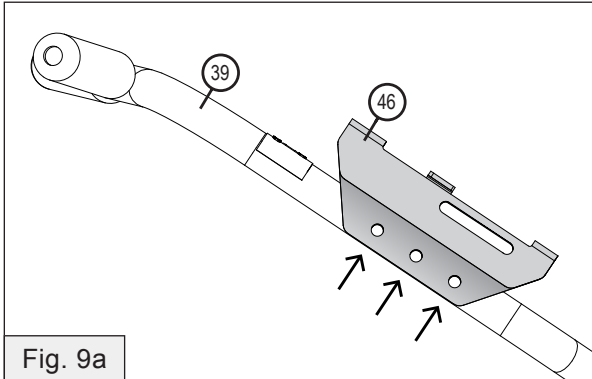

Fig. 9a

- The lip of the the Winter Gauge (46) needs to be **POINTED OUT & AWAY** from the handle tubing (39). See Fig 9b

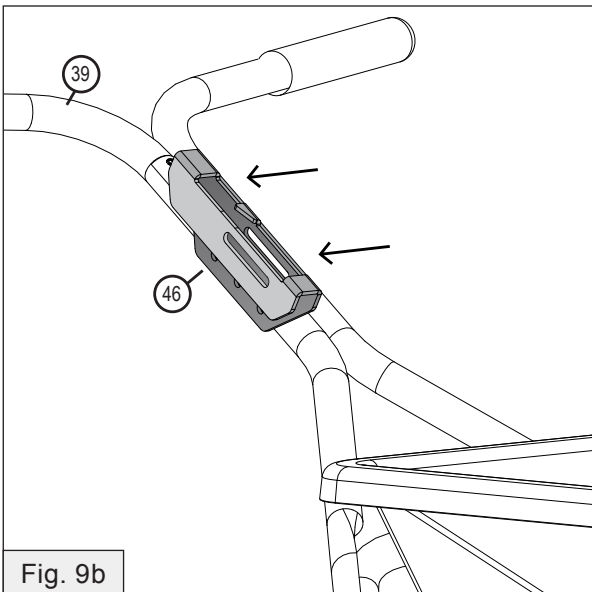

Fig. 9b

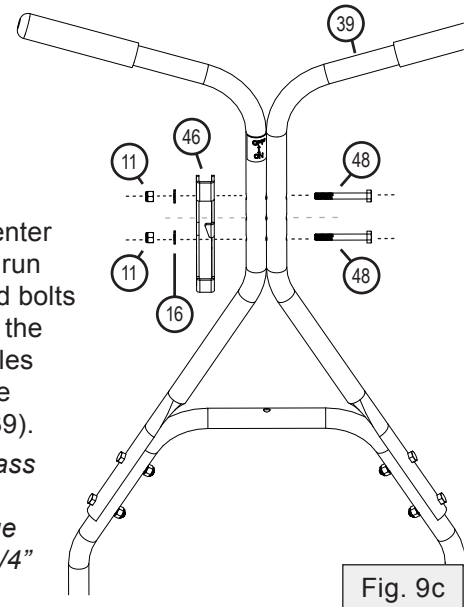

Fig. 9c

- Leave the center hole open & run two hex head bolts (48) through the outer two holes of the Handle Weldment (39). Bolts then pass through the Winter Gauge (50) & one 1/4" washer (16) goes on the end of each bolt.

- Add one Nylon Lock Nut (11) on the end of each Bolt (51).

10. Adding the Control Lever.

The Control Lever (43) slides through the Winter Gauge (46) that was added on step 9.

Align the central hole of the Lever (43) with the central hole under the Winter Gauge.

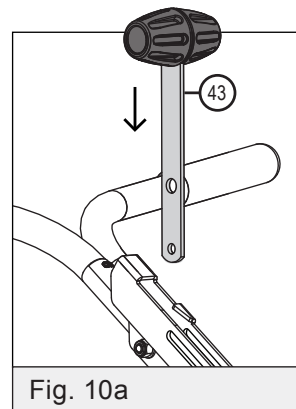

Fig. 10a

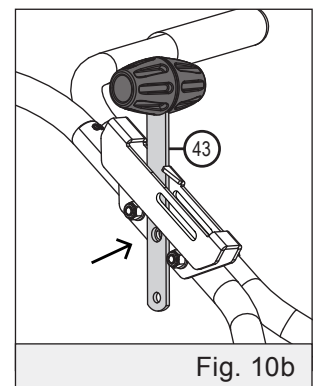

Fig. 10b

- 11. Run the longest bolt (49) through the last remaining hole of the handle tubing (39) / Winter Gauge (46) and the center hole of the Control Lever (43).

- Add a Nylon Flange Bushing (15) to the bolt and push the protruding edge of the bushing into the center hole of the Control Lever (43), locking it in place.

Assembly

11. Continued...

- Add the Control Lever Spring (44) and a Nylon Washer (41) to the bolt.
- Add a Nylon Lock Nut (11) on the end of the bolt. Tighten enough to allow movement.

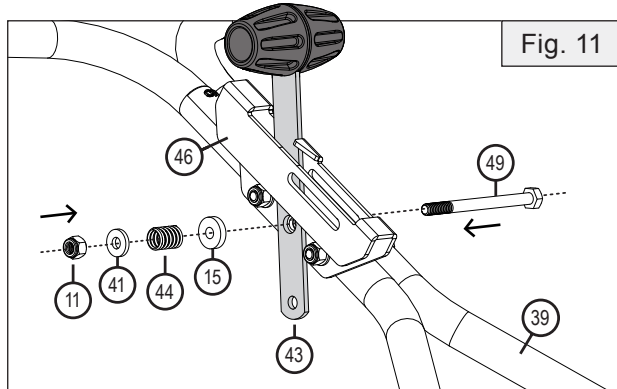

12. Find the oblong slots on the Winter Gauge (46). Drop the plastic spacer (73) and external tooth washer (74) down into the center of the Winter Gauge (46) together, aligning them with the lowest point of the oblong slots.

Run the Carriage Bolt (72) through the Winter Gauge (46), spacer (73) and external tooth washer (74).

Secure in place with a knob (75).

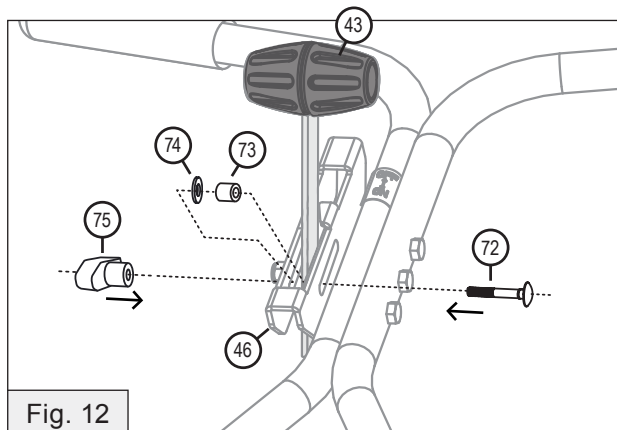

13. Adding the Linkage.

The Linkage Rod (50) has threading on one end & the other end has a Z-bend.

Slide the end of the Linkage Rod (50) with a Z-bend into the bottom of the Control Lever (43).

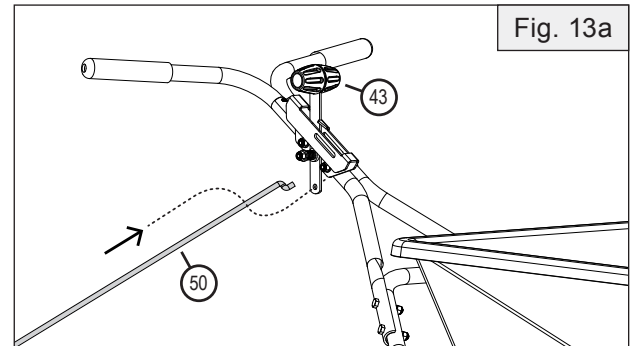

The lower hole of the linkage Guide Plate (51) slides over the end of the Linkage Rod (50). Be sure the plate (51) is facing the correct direction. See figure 12b.

While holding the Plate halfway up the Rod, lower the Rod and rotate it toward the hopper. The top hole of the Guide Plate (51) should align with the interior hole at the center of the Lower Handle tubing (52).

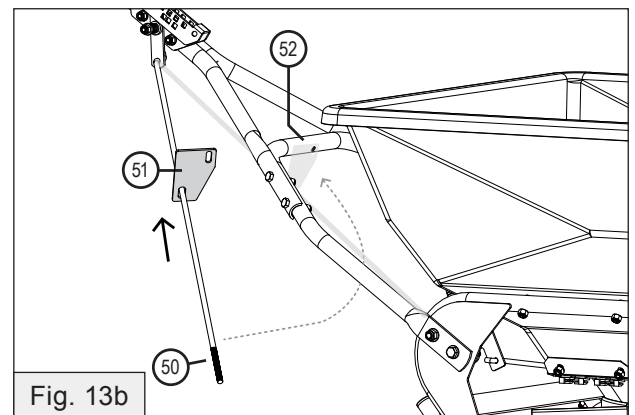

The threaded end of the Linkage Rod (50) will need a Nut (19) added to the end, followed by a Lock Washer (20). Locate the Angled Bracket (21) that is located at the base of the spreader. This bracket needs to be rotated towards the handle of the spreader. See figure 13c.

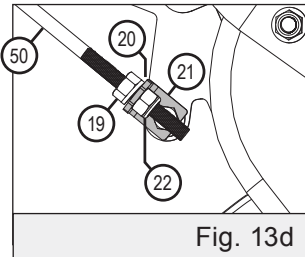
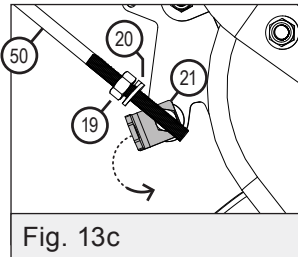
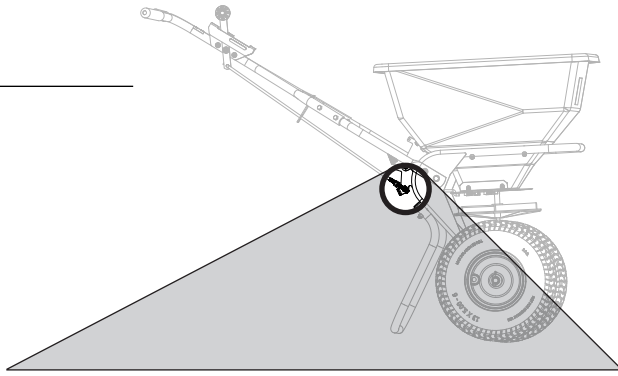

Tighten the nut (19) towards the angled bracket (21), then add a Nylon Lock Nut (22) to the end of the Linkage Rod (50), securing the linkage in place. See figure 13d.

Return the Control Lever (43) to the closed position.

Look inside the hopper & verify rate gate is completely CLOSED.

The location of the angled bracket (in relation to the end of the linkage rod) will effect rate gate opening.

Nuts (19) and (22) can be moved up or down the linkage rod to adjust the rate gate opening.

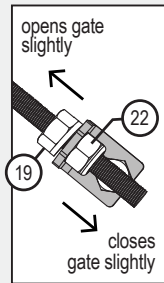

14. Securing the Linkage Guide.

The Linkage Plate Guide (51) that was added on Step 13 needs to be secured against the Lower Handle tubing (52).

- Run a Hex Head Bolt (40) through the last remaining hole of the Lower Handle tubing (52) at a downward angle starting above the tubing and passing through, pointing toward the hopper of your spreader.
- Slide the Linkage Plate Guide (51) up and add it to the bolt using the hole at the top of the plate.
- Secure in place with a Washer (16) and Nylon Lock Nut (11). Tighten completely.

14. Continued...

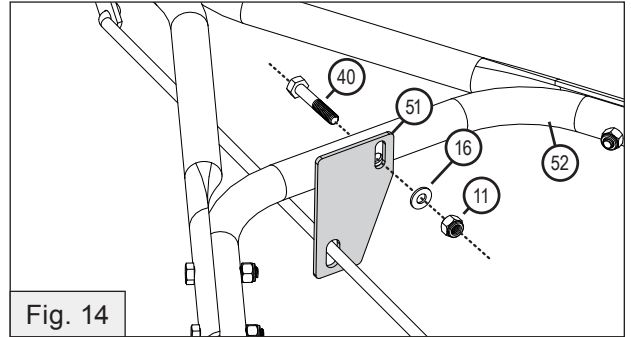

15. Screen & Hopper Cover

Place the Screen (68) down inside the hopper.

Attach the Hopper Cover (67) by hooking it around the rim of the Hopper (69).

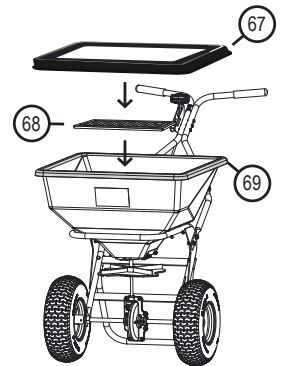

16. Adding Deflector

Slide the Deflector (76) into the Frame (58) as illustrated below. Run a Carriage Bolt (77) through the frame toward the center of the spreader. Secure in place with a Deflector Knob (75). Repeat on the other side.

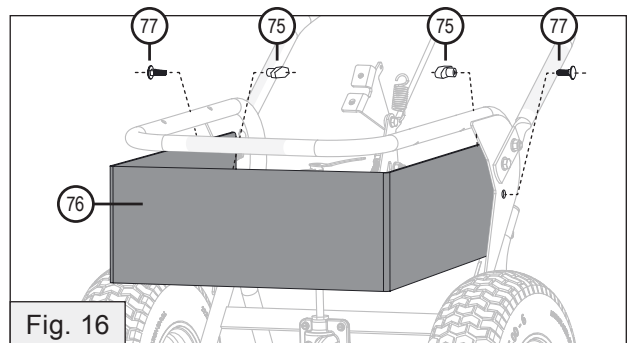

ASSEMBLY IS COMPLETE

Operation Instructions

⚠ WARNING: AVOID INJURY!

Chemicals can be dangerous. Avoid injury to operators or bystanders

NOW YOU ARE READY TO PUT MATERIAL IN THE HOPPER

- Make sure the rate gate is in the closed position.
- Read chemical container label for handling instructions. A Material Safety Data Sheet (MSDS) should be supplied by the chemical dealer and provides proper safety information.
- Wear proper clothing and safety equipment while handling or applying chemicals.
- Prohibit all smoking, drinking, and eating around chemicals.
- When spreading products containing herbicides, exercise extreme caution with respect to careless spreading and to wind-drift. Contact Of Some Products On Some Plants Can Be Fatal.
- Fill the spreader on a flat, level surface only. Fill on sidewalk, driveway, cardboard, etc. to avoid material loss.
- When filling hopper with material, always use screen to help break up clumps.

NOW YOU ARE READY TO SPREAD

- Keep spinner blade clean. Excess material build-up can cause an uneven spread pattern.
- Keep the spinner blade level when spreading.
- DO NOT overload. Maximum capacity of this model is 100 lbs.
- DO NOT use on windy days.
- Spread header strips at the ends of the area OPPOSITE of the direction of spreading. This will provide a “turn-around” area, an area to re-align the spreader for the return spread.
- TAKE A SIGHTING AT THE FAR END. Keep your eye on the sighting as you spread. You will not need to wonder where you are or where you have been. Continue until spreading is completed.

TIPS:

- Become familiar with the spreader before you put material in the hopper.
- Practice walking with the spreader, opening and closing the rate gate at the appropriate times.
- Travel at a constant speed and operate the spreader lever position.
- When you're not spreading (and if pushing the spreader some distance) tip the spreader so only the idle wheel is on the ground.
- The spread width ranges from 4 - 12 ft. wide depending on the density of the material & the operators walking speed.
- The spread thins or feathers at the outer edges, eliminating sharp, “Edge Of Spread” lines which cause stripes & streaks. Extra coverage can be given under trees and other heavy feeding areas without showing “Edge Of Spread” lines.
- Some products can be fatal to some plants.
- Always remove material from hopper before attaching spreader on a vehicle-mounted spreader caddy.

AFTER USE / CLEANING THE SPREADER:

CLEAN AND OIL SPREADER IMMEDIATELY AFTER EACH USE

METHOD #1	METHOD #2
Wipe spreader thoroughly with an oily cloth. Oil all bearings and bearing areas.	Wash, rinse, and dry the spreader. <i>Note: Drying takes time. Moisture trapped in bearing areas is slow to go.</i> Immediately after drying - oil all bearings and moving parts. Make certain all operations are thorough.

NOTE: Good "Dry Cleaning" (Method #1) is preferable to poor "Wet Cleaning" (Method #2).

- It is virtually impossible to have rust and corrosion on a clean, dry, oiled surface.
- Again - just before using - oil all bearings & moving parts.
- In storage, ideally the spreader should be hung by the handle. In any case, do not pile weight on the spreader, as excess weight over a period of time can distort the tires.

Oil Bearings and All Moving Parts

Make sure the spreader is running freely!

WINTER GAUGE SETTINGS

The Control Lever **43** opens and closes the Rate Gate beneath the Hopper of your spreader.

To adjust the Rate Gate Opening:

1. Lock the Control Lever **43** in the closed position.
2. Unscrew the Winter Gauge Knob (75) slightly and slide it along the slot. As this knob slides toward the handle, your Rate Gate will open less.
3. Tighten the Winter Gauge Knob (75) when it is in the desired setting for your Rate Gate Opening.

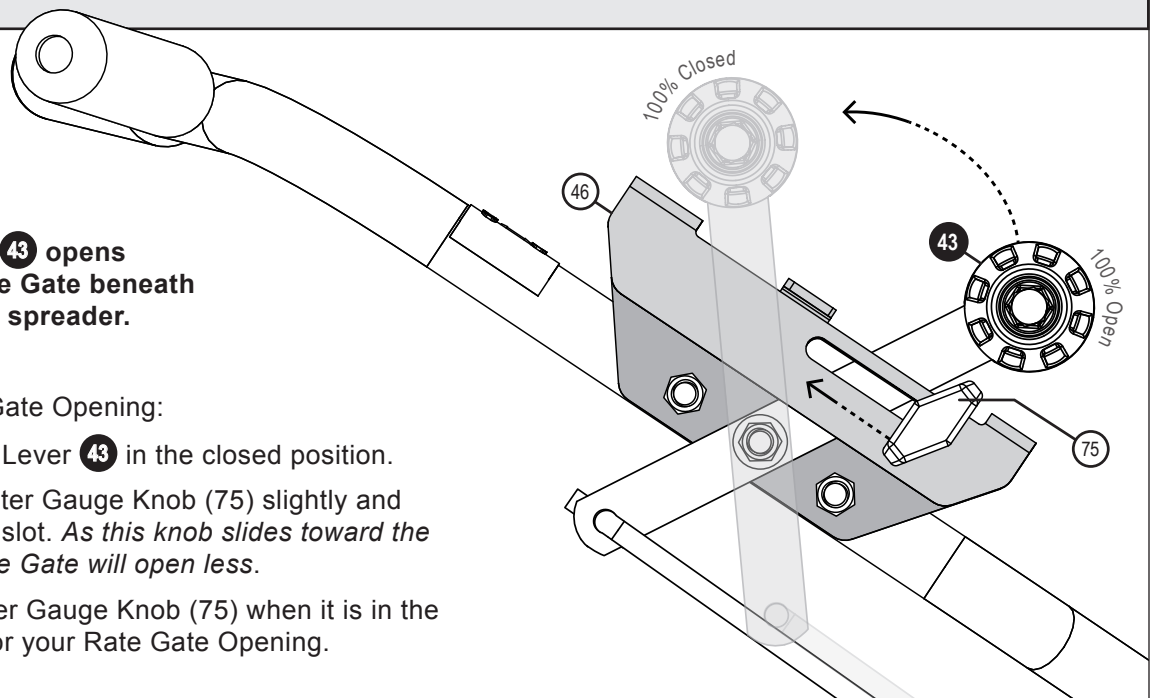



WARRANTY

1 YEAR LIMITED WARRANTY

This is warranted to the original purchaser only. Spyker will replace parts with defects in materials and workmanship, for a period of one year from the date of purchase.

For Spyker Spreaders—a Brinly-Hardy Company, products employing metal gear systems, pinion and bevel, these metal gears, only, not inclusive of any other parts or materials, are warranted for the life of the spreader, not to be used for replacement or repair past original purchase.

Spyker Spreaders will not be liable for any loss, damage or expense including, but not limited to, consequential or incidental damages, arising from the operation, condition or use of the item. The sole and exclusive remedy against Spyker Spreaders being the replacement of the defective parts. This warranty gives you specific legal rights, and you may also have other rights which vary from state to state.

This express warranty, which is applicable only to the original purchase, is in lieu of and excludes all other warranties, whether expressed or implied by operation of law or otherwise, including any warranty of merchantability or fitness for particular purpose.

SPYKER SPREADERS
Jeffersonville, IN 47130 USA
Phone: 800.972.6130
www.spyker.com