

Nitro Valves

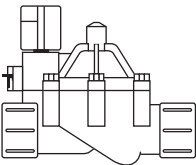

Nitro installation instructions.....2
 Instrucciones para instalar el Nitro.....4
 Istruzioni per l'installazione Nitro.....6
 Installation pour l'installation des vannes Nitro.....8
 Installationsanleitung für die ventile Nitro.....10
 Instrucoes para instalar Nitro.....12
 Nitro performance information.....14

<p style="text-align: center;">N-100</p> 	<p style="text-align: center;">N-100S</p> 	<p style="text-align: center;">N-100SF</p> 
<p style="text-align: center;">N-100F</p> 	<p style="text-align: center;">N-100MB</p> 	<p style="text-align: center;">N-100MBF</p> 

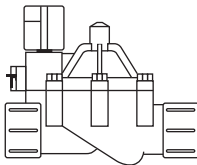
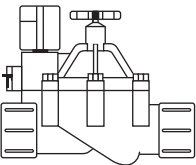
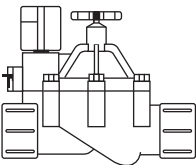
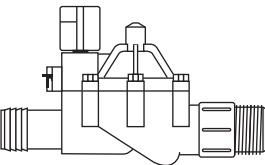
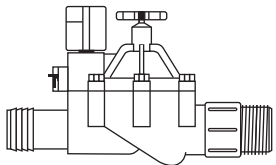

NITRO VALVE INSTALLATION AND OPERATION

Important: Flush the supply lines completely before installing valves.

- A.** For threaded models wrap male adapters with 2 wraps of Teflon tape and thread the adapters into the valve inlet and outlet 1 turn past hand tight. **CAUTION:** Over tightening may cause damage to the valve.
- B.** For slip models apply a thin coating of solvent cement to the outside of the supply line and the valve inlet. Twist the valve fully onto the supply line to evenly spread the cement. Repeat these steps for the outlet connection. The solenoid must be on the downstream side of the connection.
- C.** For barbed models slip one or two clamps over the poly pipe. Slip the poly pipe completely over the barbed outlet. Clamp the poly pipe securely to the barb.
- D.** Using watertight connectors, connect the valve common and an individual station wire to the solenoid leads.
- E.** Flush the laterals by opening the internal manual bleed lever on the downstream side of the solenoid. Turn the flow control stem fully open (counterclockwise) for flow control models.
- F.** Close the internal manual bleed after flushing the system.

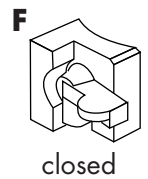
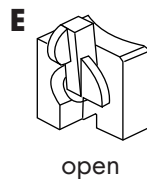
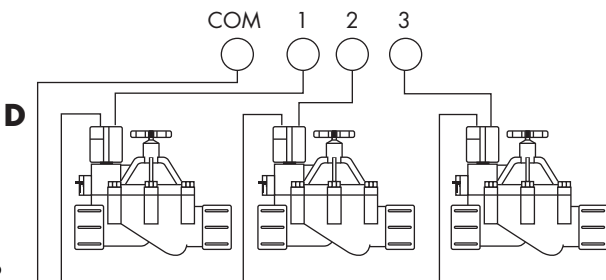
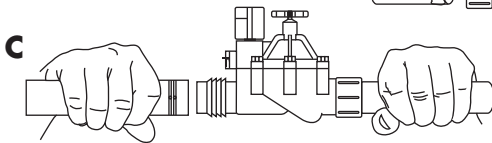
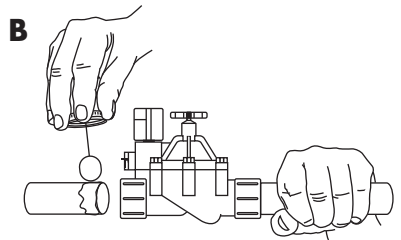
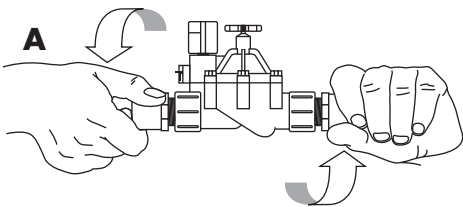



NITRO VALVE TROUBLESHOOTING

Problem	Solution
Valve will not open manually	Check water supply and any possible master or gate valves to insure they are open.
	Check that valve is installed with the arrow pointing in the downstream direction.
	Check that the flow control is fully open (counterclockwise).
	Turn off the water supply. Remove the solenoid and check for debris blocking the exhaust port.
	Turn off the water supply. Remove the cover. Inspect the diaphragm for damage and replace if necessary.
Valve will not open electrically	Check voltage at controller for 24 VAC to station.
	Check voltage across the solenoid lead wires for minimum 21 VAC.
	If the valve still does not operate electrically replace the solenoid with a Weathermatic model M24E solenoid.
Valve will not close	Insure the manual bleed lever is in the closed position.
	Check for leaks around flow control, solenoid or between valve cover and body.
	Turn off the water supply. Remove the solenoid and check for debris or damage to the exhaust port.
	Turn off the water supply. Remove valve cover and inspect for debris under diaphragm or debris in diaphragm ports
Slow leak through sprinklers	Check for dirt or gravel embedded in diaphragm seat.
	Check actuator and exhaust fitting for proper seating.