

# FLUX BOOSTING SYSTEM



## How it works

When the pressure available is insufficient it is necessary to install a boosting system. FLUX BOOSTING SYSTEM starts and stops according to the user's needs. It replaces the traditional pressure switch/tank systems, offering more advantages such as:

- Easy installation
- Reduced dimensions
- Constant flow
- Low maintenance required
- No need to install pressure tanks
- Pump protection against running dry, with automatic reset

The FLUX monitors the flow rate of the water running through and protects the pump against dangerous working conditions like running dry.

When a tap is opened and the water demand exceeds the minimum starting flow, FLUX starts the pump and keeps it running, delivering constant flow, even when capacity request is low. FLUX stops the pump when the demand is below 0.5 gal/min. In case of a leak on the system (less than 0.5 gal/min) FLUX will never start the pump avoiding useless power consumption.



Pressure Tank



Pressure Switch

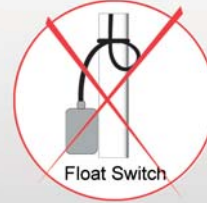

Float Switch



### SAVE:

- ✓ Money
- ✓ Space
- ✓ Installation Time

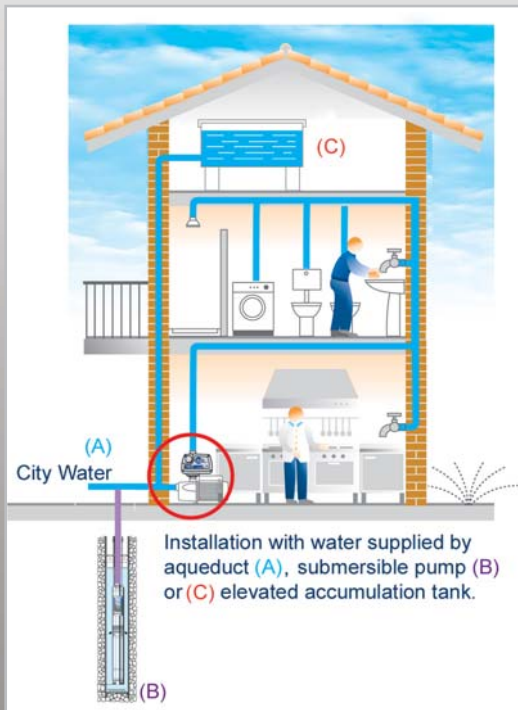

## Applications

FLUX BOOSTING SYSTEM is made up of a water pump and an electronic pump controller which is used for:

*Residential irrigation applications when is necessary to boost the pressure coming from the city water or a well pump.*

## Technical Specifications

- Voltage: 115 Volt or 230 Volt
- Water resistant
- Outdoor use
- Dimensions: see page 7
- Working temperature: 32° -104° F
- Connections: 1" standard
- Maximum working pressure: 95 psi
- Minimum flow rate: 0.5 gpm

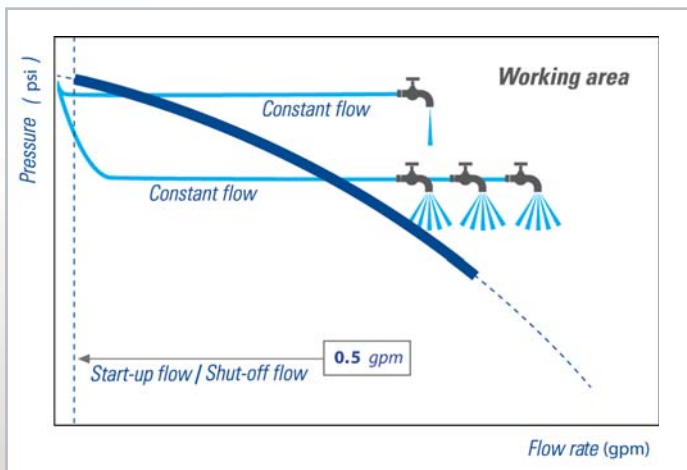

*It is recommended to install a pressure reducer valve and a surge arrester when using the FLUX BOOSTING SYSTEM (see manual)*



## Features and Benefits

- FLUX's body made of technopolymer with a built-in check valve.
- FLUX BOOSTING SYSTEM comes available with different pumps to boost in coming pressures up to 70 psi higher. For selection chart see page 6.
- Friction loss is extremely low, allowing the use of the FLUX BOOSTING SYSTEM in applications with required flows up to 50 gpm.
- The special valve guarantees the pump continuous operation.
- Circuit board is easy to replace and available in 115 V and 230 V.





## Selection Chart

### APPLICATIONS FOR MODEL: FBSMS05 15G30P

PUMP MODEL: MSC20 05 | PUMP CONTROLLER: FLUX | WATER SUPPLY: CITY WATER OR SUBMERSIBLE PUMP

Recommended

FLOW RATE (GPM)	INCOMING PRESSURE (PSI) FROM CITY OR SUBMERSIBLE PUMP				APPLICATION	PRESSURE LOSS (PSI) IN WATER METERS		
	20	30	40	50		5/8"	3/4"	1"
	PRESSURE (PSI) IN THE DISCHARGE OF THE PUMP							
Shut - off	63	73	83	93	-----			
5	60	70	80	90	1 Bathroom home	1	0.6	0.2
10	55	65	75	85	2 - 4 Bathroom home	3.7	1.6	0.7
15	50	60	70	80	5 - 6 Bathroom home	8	3.6	1.2
20	40	50	60	70	Up to 7 Bathroom home	15	6.5	2.3

### APPLICATIONS FOR MODEL: FBSMS07 17G40P

PUMP MODEL: MSC20 07 | PUMP CONTROLLER: FLUX | WATER SUPPLY: CITY WATER OR SUBMERSIBLE PUMP

Recommended

FLOW RATE (GPM)	INCOMING PRESSURE (PSI) FROM CITY OR SUBMERSIBLE PUMP				APPLICATION	PRESSURE LOSS (PSI) IN WATER METERS		
	20	30	40	50		5/8"	3/4"	1"
	PRESSURE (PSI) IN THE DISCHARGE OF THE PUMP							
Shut - off	90	100	110	120	-----			
5	80	90	100	110	1 - 2 Bathroom home	1	0.6	0.2
10	75	85	95	105	3 - 4 Bathroom home	3.7	1.6	0.7
15	65	75	85	95	5 - 6 Bathroom home	8	3.6	1.2
20	55	65	75	85	Up to 7 Bathroom home	15	6.5	2.2

### APPLICATIONS FOR MODEL: FBSMS07 25G30P

PUMP MODEL: MSC30 07 | PUMP CONTROLLER: FLUX | WATER SUPPLY: CITY WATER OR SUBMERSIBLE PUMP

Recommended

FLOW RATE (GPM)	INCOMING PRESSURE (PSI) FROM CITY OR SUBMERSIBLE PUMP				APPLICATION	PRESSURE LOSS (PSI) IN WATER METERS		
	20	30	40	50		5/8"	3/4"	1"
	PRESSURE (PSI) IN THE DISCHARGE OF THE PUMP							
Shut - off	66	76	86	96	-----			
10	62	72	82	92	3 - 4 Bathroom home	3.7	1.6	0.7
20	56	66	76	86	Up to 7 Bathroom home	15	6.5	2.2
30	48	58	68	78	Large homes long runs of plumbing	-	15	5.3
35	40	50	60	70	Large homes or large irrigation systems	-	-	6.9

- All calculations done based on 3 gpm per outlet.
- All calculations done based on 1 floor/level home.
- The pressure at the discharge of the pump does not include the pressure loss in the water meter.
- It is recommended for residential applications, 75 psi maximum discharge pressure in order to prevent damage to piping. If the pressure at the discharge of the pump is higher than 75 psi it is recommended the installation of a pressure reducing valve.
- This calculations do not take into consideration the irrigation system.
- When a water meter is installed at the suction line there are pressure losses that will affect the total pressure in the system. When the pressure loss is higher than 5 psi, it is recommended to install a larger water meter.

**DIMENSIONS**

**FBSMS05 15G30P**  
**FBSMS07 17G40P**  
**FBSMS07 25G30P**

**WEIGHT=**  
**19.6 lbs / 26.7 lbs**

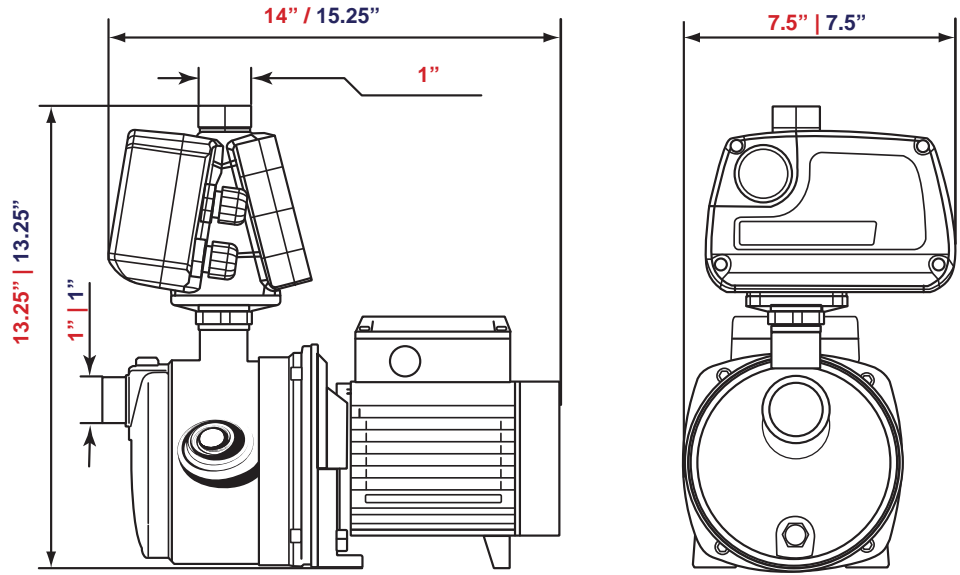

BEFORE INSTALLING THE PUMP, BE SURE THAT THE MAXIMUM FLOW OF THE WATER METER WILL NOT BE EXCEEDED (SEE REFERENCE).

REFERENCE	
METER SIZE	MAX FLOW (GPM)
5/8"	12
3/4"	30
1"	40

*It is recommended to install a pressure reducer valve and a surge arrestor when using the FLUX BOOTING SYSTEM(see manual)*