



**DL1302H, DL1402SE, DL1802V, DL1802VE Owner's Manual**



## **DL Truck Loader Vacuum Owner's Manual**

DL1302H, DL1402SE, DL1802V, DL1802VE

### **Original Instructions**

IMPORTANT- READ CAREFULLY BEFORE USE AND KEEP FOR FUTURE REFERENCE

NOT FOR SALE IN CALIFORNIA

# Specifications

## DIMENSIONS

Overall Length	31" (0.79 m)
Overall Width	27" (0.69 m)
Overall Height	48" (1.2 m)
Total Unit Weight	220lbs (DL1302H) & 280lbs (DL1402SE, DL1802V/VE)
Maximum Operating Slope	25°

Note: Battery is not included! Your unit requires a 12V battery (40AH, 240CCA min., U1 series group) for proper fit and function.

## ENGINE

### Fits Models: DL1302H

Engine: Model	GX390UTQA2
Engine: Type	Honda
Engine: Fuel Capacity	6.9qt (6.5L)
Engine: Oil Capacity	1.16qt (1.1L)

## ENGINE

### Fits Models: DL1402SE

Engine: Type	EX400DS6030*1
Engine: Model	Subaru
Engine: Fuel Capacity	7.4qt (7.0L)
Engine: Oil Capacity	1.3qt (1.2L)

## ENGINE

### Fits Models: DL1802V

Engine: Model	3564420298F1
Engine: Type	Briggs and Stratton
Engine: Fuel Capacity	9.00qt (8.52L)
Engine: Oil Capacity	1.75qt (1.66L)

## ENGINE

### Fits Models: DL1802VE

Engine: Model	3564470299F1
Engine: Type	Briggs and Stratton
Engine: Fuel Capacity	9.00qt (8.52L)
Engine: Oil Capacity	1.75qt (1.66L)

assembly. Follow the safety rules closely. Failure to obey these rules could result in loss of control of the unit, severe personal injury or death to you, or bystanders, or damage to property or equipment.

The safety alert triangle (⚠) in text signifies important cautions or warnings which must be followed.

## Parts Bag and Literature Assembly

Item	P/N
Warranty Card	400972
Operator's Manual	812507
General Safety and Warnings Manual	100294
Illustrated Parts Book	812509
Ratchet Strap	792270

## Safety Interlock System

With hose coupler installed (as shown in Figure 1) the switch is open and engine is not grounded out, allowing engine to run. Hose must be installed over the switch and the switch lever must engage switch for engine to start.

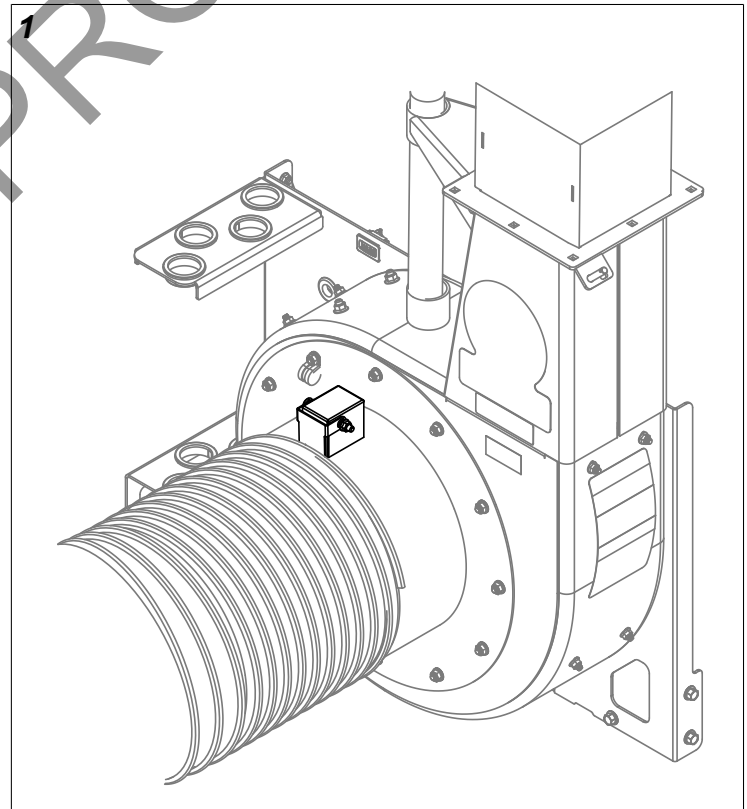

# Operating Safely

Read the safety rules outlined in the General Safety and Warranty Manual included with this Operator's Manual in your Billy Goat Debris Loader parts bag and literature

## Safety Decals

2



A



B



D



F



H



C



E

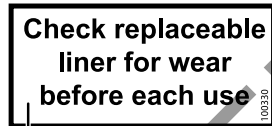

G



I

Item	Part Number
A	811215
B	790232
C	790142
D	400268
E	400424
F	810736
G	100330
H	790301
I	100252

## Packing Checklist

Your Billy Goat Debris Loader is shipped from the factory in one carton and requires some assembly. You must assemble the exhaust elbow, nozzle, handle loop for nozzle, hose

booms, hose bands, hose coupler, and clamps using the related hardware included.



**READ** all safety instructions before assembling the unit.

**TAKE CAUTION** when removing the unit from the box.

**ADD OIL** to the engine before starting.

*Note:* A battery is not included! Your Billy Goat Debris Loader requires a 12V, 40AH, 240CCA min. U1 series group battery for proper fit.

## Boxing Parts Checklist

3

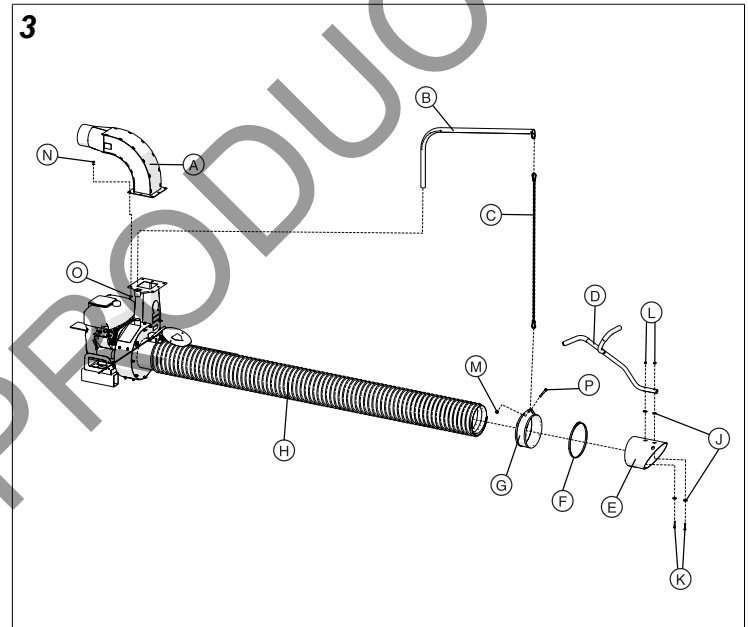

I.D.	Item	DL1302H, DL1402SE, DL1802V	DL1802VE
A	Exhaust Elbow	813600	813600
B	Hose Boom Assembly	812245	812245
C	Boom Chain Assembly	791117-S	791117-S
D	Handle Nozzle	791116-S	791116-S
E	Nozzle Intake	811007-S (8") 811005-S (10")	811005-S (10")
F	Hose Clamp	810566 (8") 810706-01 (10")	810706-01 (10")
G	Band Hose Boom	810880 (8") 810868 (10")	810868 (10")
H	Hose	811244 (8") 791033-S (10")	791033-S (10")
J	Washer (Nozzle Intake)	8172020	8172020
K	Bolt (Nozzle Intake)	8041032	8041032
L	Nut (Nozzle Intake)	8165002	8165002
M	Nut (Band Hose Boom)	8165001	8165001
N	Bolt (Elbow)	8024058	8024058

I.D.	Item	DL1302H, DL1402SE, DL1802V	DL1802VE
O	Nut (Elbow)	8165003	8165003
P	Bolt (Band Hose Boom)	8041013	8041013

## Initial Set-Up Assembly Hardware

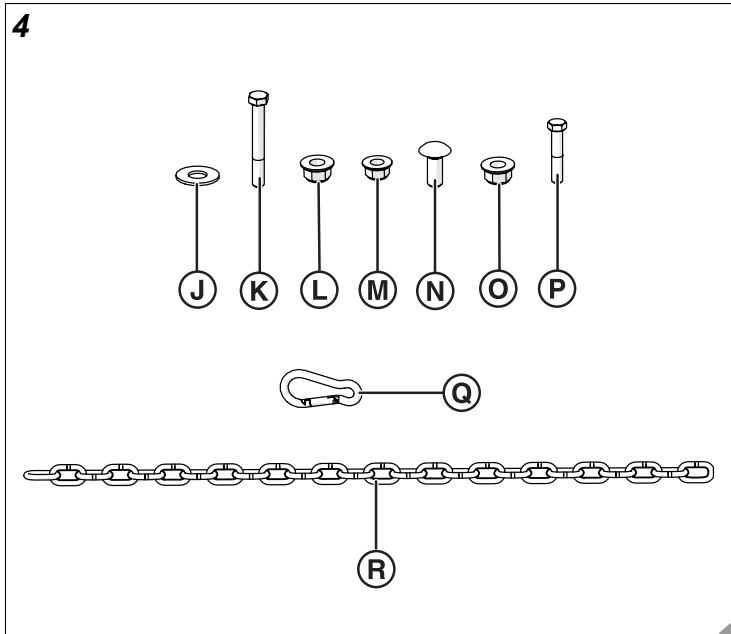

I.D.	Part Number	QTY
J	8172020	4
K	8041032	2
L	8165002	2
M	8165001	1
N	8024058	8
O	8165003	8
P	8041013	1
Q	791027	2
R	791057	1

## Assembly

### Mounting Main Unit

This unit must be securely mounted to a trailer, truck bed, or other similar surface before use. Do not use this unit in a freestanding position. Unit is not stable until it has been secured in place. Secure unit by bolting through the base of the unit and through the mounting surface using 3/8" bolts, with washers and locking nuts.

### Initial Set-Up Assembly

- Securely attach unit to the bed of a truck or to a trailer, so that the exhaust discharges into an enclosed container.
- Attach the hose boom to hose by sliding the boom through the rings on the top of the housing.
- Slide the hose onto the housing intake, ensuring the shut off switch is positioned under the hose or the vacuum will not start (See the Safety Interlock System section of this manual). Then place the ratchet strap over and around the end of the hose to secure it to the housing. **Note:** The ratchet strap is located in the Parts Bag and Literature Assembly.
- Assemble nozzle handle to nozzle intake using bolts, washers, and nuts (items J, K, and L in Figure 4).
- Attach assembled nozzle to hose using hose clamp. Before tightening hose clamp, position nozzle handle upward when hose is stretched to prevent twisting. Load on hose assembly during operation.
- Assemble hose band around hose and secure chain between the flanges of the hose band using capscrew and lock nut. Attach the chain to the boom and the screw on the hose band. See "Adjusting the Hose Boom" for more information.
- Securely attach exhaust elbow with the nuts and bolts (items N and O in Figure 4).

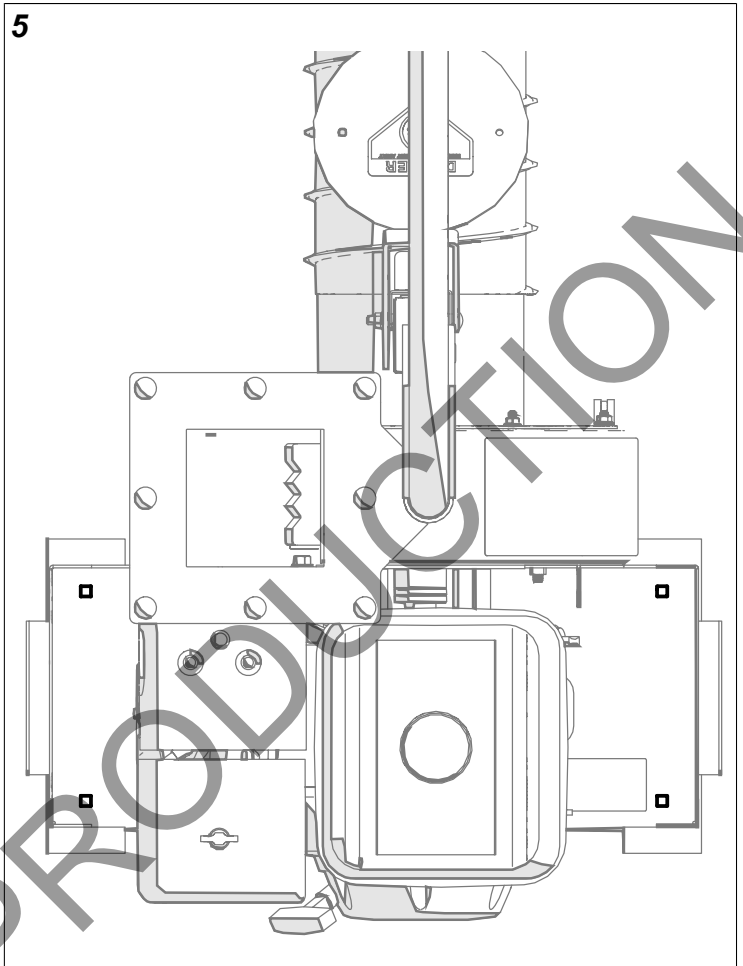

8. Install a standard 12 volt lawn and garden battery “U1” series (not included) with at least 240 cold cranking amps and a 40 amp hour rating by using battery bracket, hold down rods, washers and lock nuts. Only models DL1402SE and DL1802VE require a battery.
9. Attach the red battery cable to the + terminal and the black battery cable to – terminal on the battery.

## Operation

### Vacuumping Operation

**Important:** With the machine off and spark plug disconnected, check the condition of the replaceable liner before every use and replace if necessary.

**Exhaust Direction and Distance:** Exhaust direction and distance are controlled by the rotation of the exhaust elbow. Typically debris is aimed to discharge to the rear of the container. The direction of discharge is adjusted by rotating the exhaust elbow in the desired direction then securing the elbow to the housing with the hardware provided. See the Initial Set-Up Assembly section for instructions on how to mount the elbow.



#### CAUTION

Elbow is heavy. Use caution when adjusting. Never stand directly under the elbow while adjusting direction of exhaust. Never direct exhaust into an area where bystanders may cross the path of the debris.

**Intake Operation:** With the fully assembled machine running, move the nozzle in sweeping motions over debris. Always allow air to flow into the nozzle along with the debris. Do not completely block the nozzle when vacuuming as it will reduce performance and increase clogging.

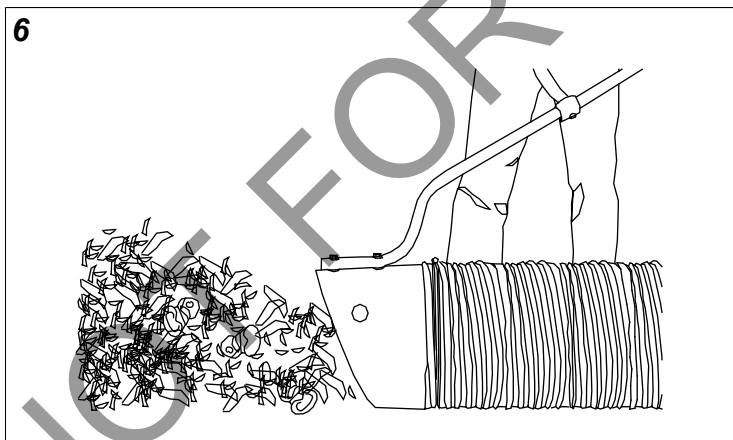

For removal of heavier debris, or debris that is stuck to the ground, rock nozzle forward to concentrate suction power around the debris.

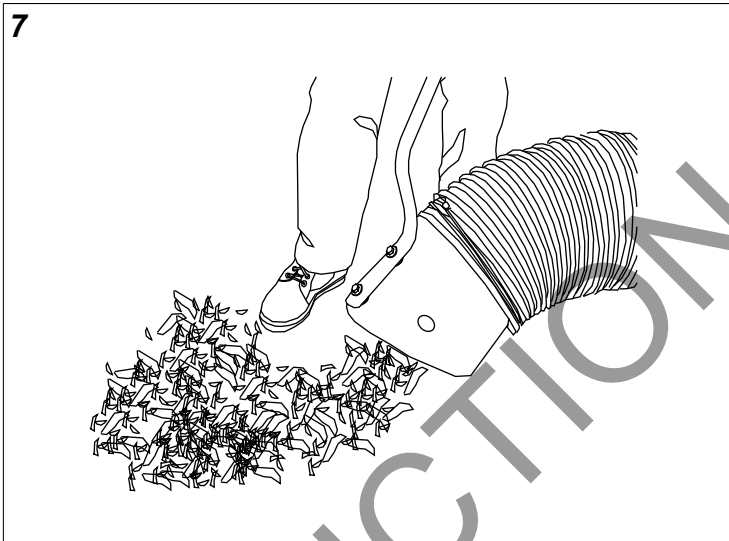

### Adjusting Hose Boom

Properly adjusting the boom prevents most hose clogs from occurring and maximizes vacuum performance by keeping the hose straight and perpendicular to the housing. Raise or lower one of the attachment links to a different area on the chain to make height adjustments.

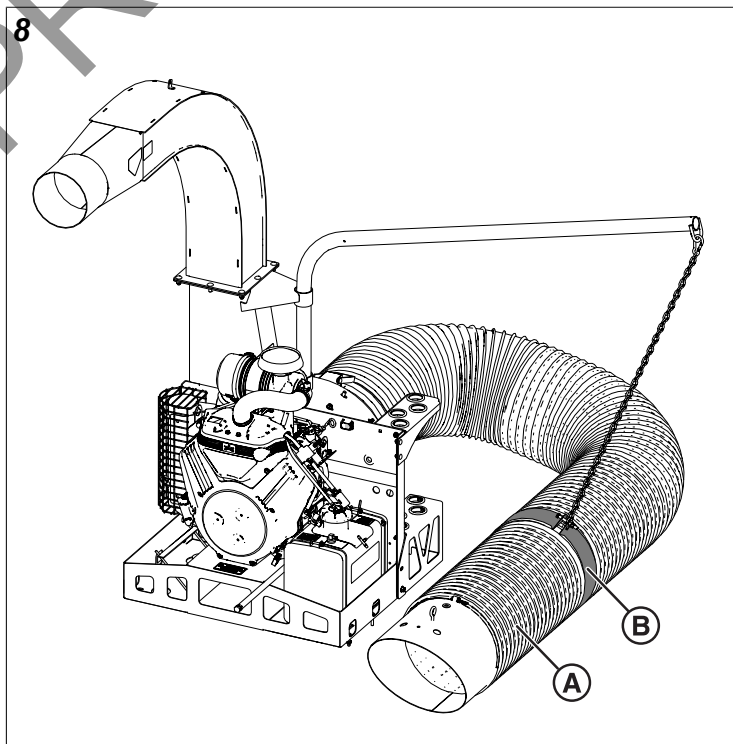

I.D.	Description
A	Hose
B	Hose Band (stretch out the hose before clamping)

### Hose Care

To increase hose life, periodically rotate hose and position nozzle and coupler on the front plate of the unit. This ensures

that the hose will not wear on only one side, further increasing its life.

Keep the hose as straight as possible and avoid sharp bends during operation for best pick-up and to avoid clogs. Never drag the hose. Always remove and store the hose before transporting the unit. Store hose straight and flat to maintain flexibility for next use.

## Battery Care

This procedure is for electric-starting models only.

Proper care can extend the life of a battery. Follow these recommendations to ensure your battery's best performance and long life:

- Do not allow the battery charge to get too low. If the machine is not used, charge the battery every 4 – 6 weeks with a 2 amp battery charger. Operate the engine for at least 45 minutes to maintain proper battery charge.
- Store an unused battery in a dry area that does not freeze.
- Do not charge an already charged battery. In theory, you cannot overcharge our battery with a trickle charger; however, when a battery is fully charged and the charger is still on, it generates heat that could be harmful to the battery. A fully charged battery will read 12V-13.2V with a voltmeter.
- Do not continue to crank your engine when the battery charge is low.

## Maintenance Procedures

### Unclogging a Clogged Hose

With engine running and unit secured to a trailer, truck bed, or other similar surface, fully stretch hose in a straight line to dislodge the clog. If the clog will not clear, turn the unit off and allow engine to come to a complete stop. Remove hose and manually clear the hose clog.



#### CAUTION

The clogged debris may be sharp. Always wear durable gloves when removing clogs.

### Unclogging a Clogged Housing or Exhaust Elbow

1. Turn off engine and wait for impeller to come to a complete stop.
2. Disconnect spark plug wires and battery cables.
3. Remove the hose from the housing and determine where the clog is located.
4. If possible, clear the clog through the intake opening. It may require removal of the intake adapter to allow access to clear the housing.
5. If clog is in the elbow, carefully remove the elbow and clear the clog.



#### CAUTION

Elbow is very heavy. Do not stand directly under elbow during removal.



#### DANGER

The clog may contain sharp materials. Clear the clog wearing durable gloves.

6. Reconnect the spark wire.

### Replacing the Liner

1. Remove the strap securing the hose to the front plate.
2. Gently wiggle the hose off front plate.
3. Remove the front plate. Use a 1/2" wrench to loosen the front plate nuts. Slide off the front plate and set aside.

*Note:* DL9-13 series will have six (6) front plate nuts. DL14-18 series will have ten (10) nuts. DL29-37 series will have twelve (12) nuts.

4. Remove the elbow. Use a 9/16" wrench to loosen the eight (8) nuts and bolts that secure the elbow to the housing flange.



#### CAUTION

Elbow is very heavy. Do not stand directly under elbow during removal.

5. Remove the ten (10) nuts and bolts that secure the liner to the housing. Use a 3/16" Allen wrench on the button-head bolts. Simultaneously use a 1/2" wrench on the nuts to loosen the hardware.
6. With the hardware securing the liner removed, reach into the elbow-to-housing transition. Grasp the liner and pull it out through the top of the transition.
7. Slide the new liner into the housing through the elbow-to-housing transition. Reattach the hardware removed in Step 5 to secure the new liner to the housing.
8. Reverse Steps 2-4. When reattaching the hose, position the hose over the safety interlock switch. See the Safety Interlock section of this manual for more information.

### Replacing the Impeller

1. Wait for engine to cool and disconnect spark plug wires from both sides of the engine.
2. Disconnect the negative battery cable (black) from the battery.
3. Remove the hose from the unit.
4. Detach the hose from the boom assembly.
5. Remove the intake housing assembly using 9/16" socket and socket wrench to remove 12 lock nuts. Be careful to place intake assembly to the side without putting excess strain on the safety switch wire harness.

- Remove impeller bolt and lock washer by using an impact wrench. See Figure 9.

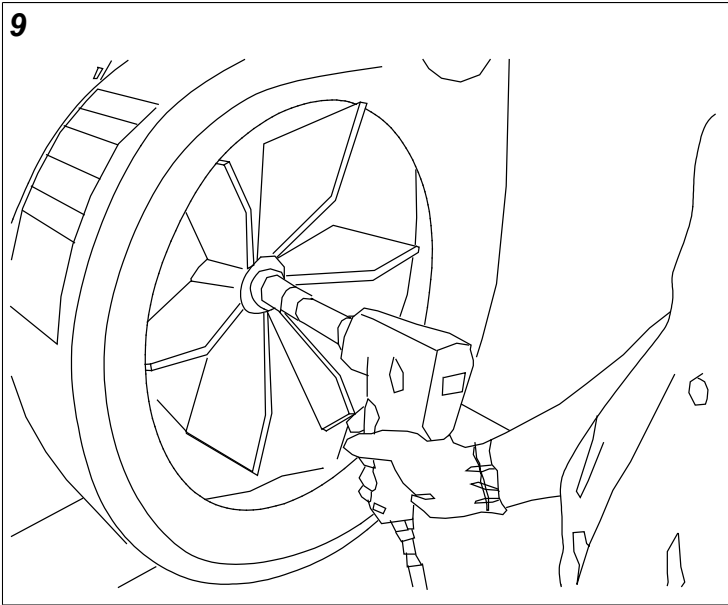

- Slide the impeller out.
- When impeller is free of the engine shaft, align impeller with the opening and pull it straight out of the housing.
- Using a new impeller bolt, washer, and lock washer, install the new impeller in reverse order.

- Tighten impeller bolt. Torque impeller bolt to 33-38 ft.lbs (45-52 N.m) for DL9-18 series. Torque impeller bolt to 175-180 ft.lbs (237-244 N.m) for DL29-37 series.
- Repeat steps 2 through 5 in reverse order.
- Install spark plug wires.

## Charging the Battery

Operate the engine for at least 45 minutes to maintain proper battery charge. If the battery loses its charge, you will need to use a trickle charger to recharge it.

**NOTICE** The charger should have an output of 12 volts at no more than 2 amps. Using a charger with higher amps will cause significant damage to the battery.

- At 1 amp, the battery may need charging for as long as 48 hours.
- At 2 amps, the battery may need charging for as long as 24 hours.

*Note:* Using the Recoil Starter, then running the engine will NOT recharge a dead or significantly discharged battery.

*Note:* When the battery is completely charged, disconnect the charger from the outlet first. Then disconnect the battery charger wires from the battery. If the battery charger wires are connected to the battery, the battery will discharge itself.

## Periodic Maintenance

Maintenance Operation	Each Use	Every 50 Hrs	Every 100 Hrs	Every 250 Hrs	Every 300 Hrs
Check engine oil	X				
Change engine oil			X		
Check air filter	X				
Clean air filter		X*			
Replace air filter					X*
Check/Adjust spark plug	X				
Replace spark plug			X		
Inspect battery for corrosion or leaks	X				
Inspect battery terminal for corrosion		X			
Check/Adjust valve clearance				X	
Check thickness of replacement liner for wear	X				
Check and clean engine of debris	X				
Clean hose	X				
Inspect for loose, worn, or damaged parts	X				
Check for excessive vibration	X				
Clean truck loader	X				
Check condition of fuel lines			X		
Check tightness of hardware			X		

\* Or as needed

NOT FOR REPRODUCTION



# Wiring Diagrams

Figure 10: DL1302H Wiring Diagram

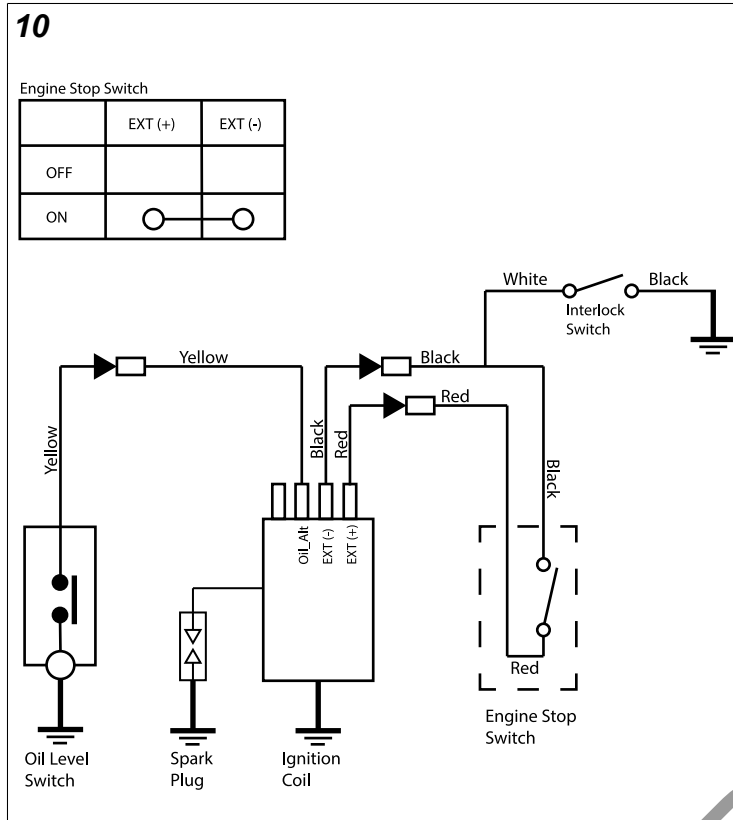

Figure 11: DL1402SE Wiring Diagram

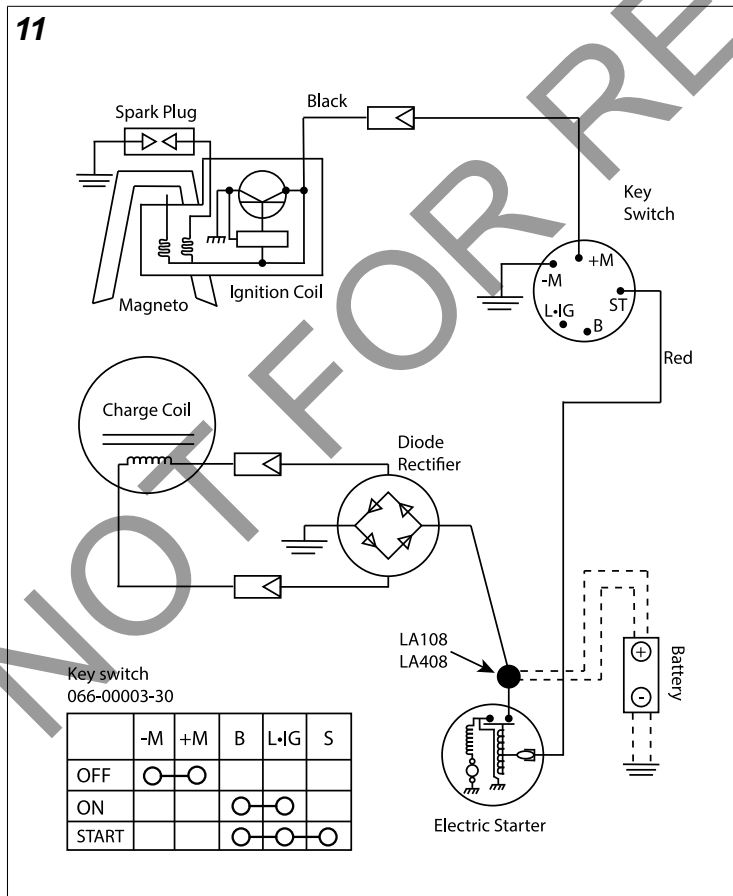

Figure 12: DL1802V Wiring Diagram

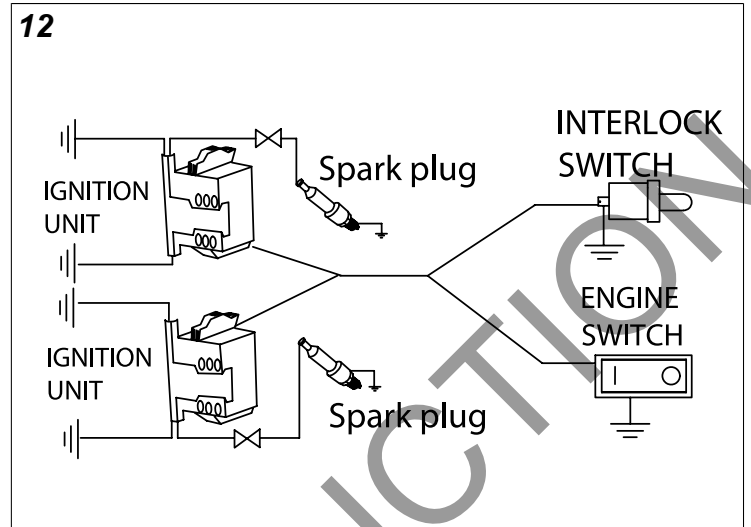
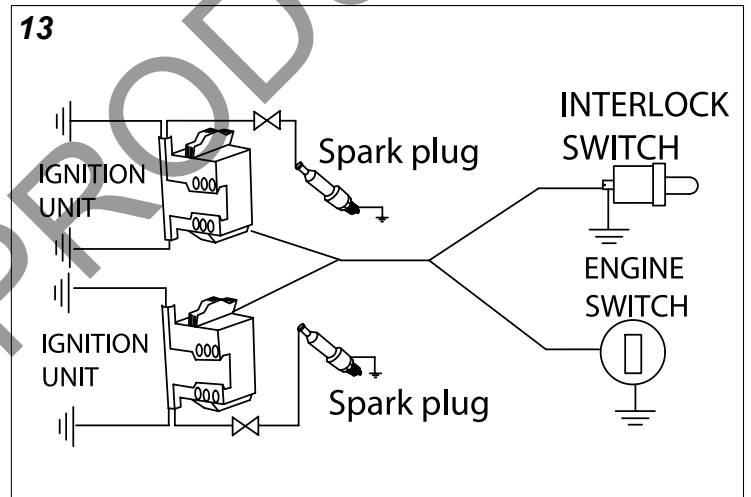

Figure 13: DL1802VE Wiring Diagram



# Troubleshooting Table

Problem	Possible Cause	Solution
Will not vacuum or has poor vacuum performance	<ul style="list-style-type: none"> <li>• Nozzle is buried in debris</li> <li>• Hose or exhaust is clogged</li> <li>• Excessive quantity of debris</li> </ul>	<ul style="list-style-type: none"> <li>• Withdraw the nozzle from the debris pile</li> <li>• Unclog the hose or exhaust (See Maintenance section for more details)</li> </ul>
Engine will not start. (Starter does not turn)	<ul style="list-style-type: none"> <li>• Battery is low or dead</li> <li>• Battery cable is disconnected or battery terminal is corroded</li> <li>• Harness wire is bad or disconnected from interlock switch</li> </ul>	<ul style="list-style-type: none"> <li>• Charge the battery or replace if the battery cannot hold a charge</li> <li>• Clean the battery terminal and cable, then reconnect</li> <li>• Install hose coupler securely to the unit and check whether the interlock switch is engaged by the lever</li> <li>• Check the wire harness connection</li> </ul>
Engine will not start, but starter turns	<ul style="list-style-type: none"> <li>• Throttle and/or stop switch is in the "OFF" position</li> <li>• Engine is out of gasoline</li> <li>• Gasoline in engine is bad or old</li> <li>• Spark plug wire is disconnected</li> <li>• Air filter is dirty</li> </ul>	<ul style="list-style-type: none"> <li>• Check stop switches, throttle, and gasoline</li> <li>• Connect the spark plug wire</li> <li>• Clean or replace air filter</li> <li>• Contact qualified service personnel if necessary</li> </ul>
Engine is locked and will not pull over	<ul style="list-style-type: none"> <li>• Debris is locked against the impeller</li> <li>• Engine has performance issues</li> </ul>	<ul style="list-style-type: none"> <li>• See Maintenance section "Unclogging a Clogged Housing or Exhaust Elbow" and follow the instructions</li> <li>• Contact an engine servicing dealer for engine problems</li> </ul>
Engine will not stay running	Oil reservoir overfilled	Drain oil and refill to correct level.

NOT FOR REPRODUCTION

# Accessories

Hose Replacement Kits	Exhaust Hose Kits	Trailer DL
Standard on DL units. Long, clear polyurethane hose. Available in 8", 10", 12", and 14" diameters.	Extends the exhaust distance using either flexible polyurethane or steel hose.	Heavy duty spring axle trailer designed for towing your DL. Allows unit to be mounted for pickup from rear.
8" x 16.5' Hose P/N 812390 (DL902HEU only) 8" x 10' Hose P/N 811244 (DL1302H, DL1302HEU) 10" x 10' Hose P/N 791033 (DL1402SE, DL1402SEEU, DL1802V, DL1802VE, DL1802VEU, DL1802VEEU) 12" x 10' Hose P/N 791034 (DL2901VE/VEMM) 14" x 10' Hose P/N 792208 (DL3701VE)	7" x 5' Flexible Polyurethane Hose P/N 812300 8" x 5' Flexible Polyurethane Hose P/N 791107 8" x 5' Flexible Steel Hose P/N 791106	Spring Axle Trailer P/N 791152 (DL29-37 series ONLY)

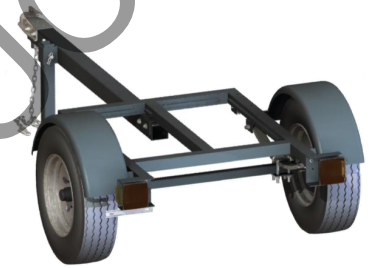
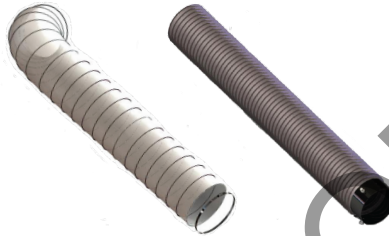

Hanging Extension Kit	Swing Away Hitch	Exhaust Extension Kit
Allows the DL to hang from a vertical side panel (not for use in transport).	Allows the DL to be attached to a hitch and swung out for easier cleanup.	Increases the height of the exhaust elbow.
P/N 812260 (DL9-18 series ONLY)	P/N SAH34 (DL9-18 series ONLY)	15.63" Extension P/N 812123-S (DL9-18 series) 12" Extension P/N 792117-S (DL29-37 series) 18" Extension P/N 792113-S (DL29-37 series) 24" Extension P/N 792119-S (DL29-37 series)

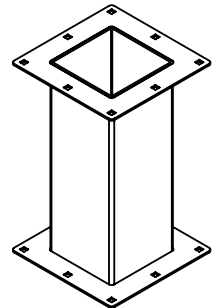
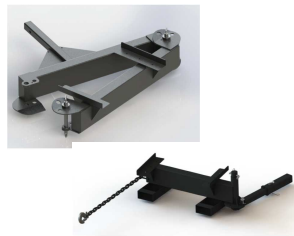

NOT FOR REPRODUCTION