

**The
Andersons**

Model 2000 SR

Professional Rotary Spreader

Assembly, Use and Care

Thank You!

You have purchased the highest quality professional broadcast spreader available on the market today. The Model 2000 SR is the accumulation of proven performance and will provide you with years of trouble-free service. In the event you should have any questions or comments, please call our professional support staff.

Our toll-free number is **1-800-225-2639** (U.S. Only)

Before You Begin ...

To assemble your new spreader, we highly recommend that you read all the instructions thoroughly, familiarize yourself with the assembly and components, and verify that all parts are included in the package.

You Will Need ...

The following tools:

- 1/2", 7/16" and 3/8" open-end wrenches (or adjustable wrench)
- Pliers
- Phillips head screwdriver
- Grease gun



Assembly

- 1) Turn the spreader upside-down. Place the wheels on the axle with the longer portion of the hubs facing inward. Secure the drive wheel "A" (right side) to the axle using the 3/16" cotter pin. Attach the idler wheel "B" (left side) to axle. Then insert the 1/8" cotter pin through the axle and secure.

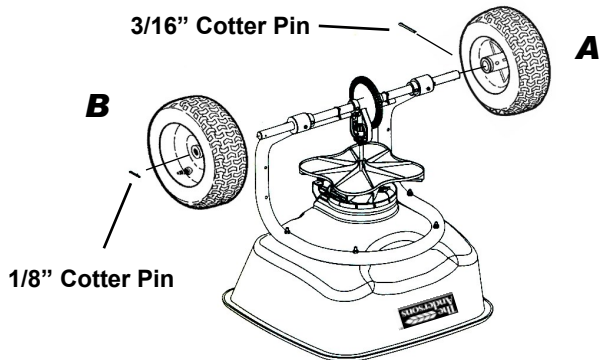

- 2) Place the spreader on its front side and attach the rest to the frame using (4) 1/4-20 x 2 1/2" Phillips screws and locknuts.

Place a drop of oil on bolt threads to ease assembly of locknuts



- 3) Return the spreader upright position and attach the upper handle to the rest with (4) 1/4-20 x 1 1/2" carriage bolts and locknuts. **Be sure that the handle lever is facing up.**

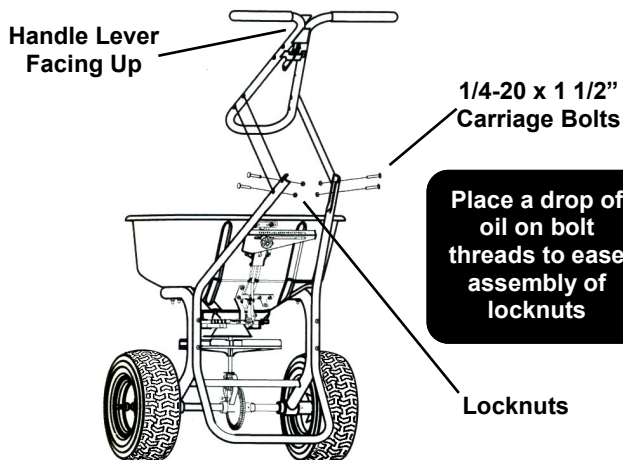

- 4) Insert the bent end of the main shutoff connecting rod through the hole in the lever and secure with a 3/32" cotter pin.

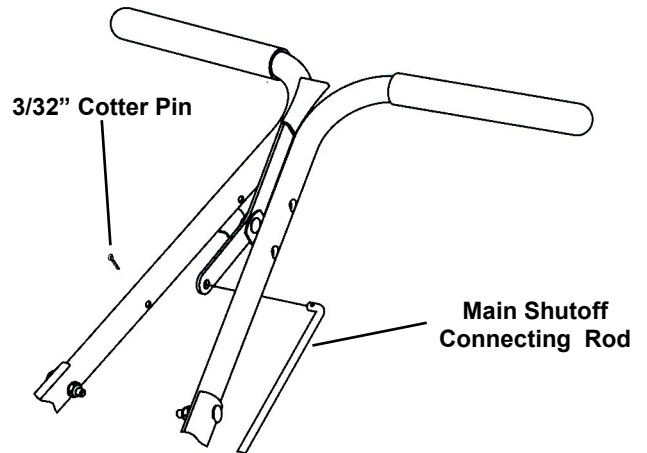

- 5) Thread one 5/16-18 hex nut onto the lower end of the main shutoff control rod until it stops. Insert the rod through the pivot lever arm as shown, and thread the second 5/16-18 nut up to the pivot lever arm; **do not tighten.**

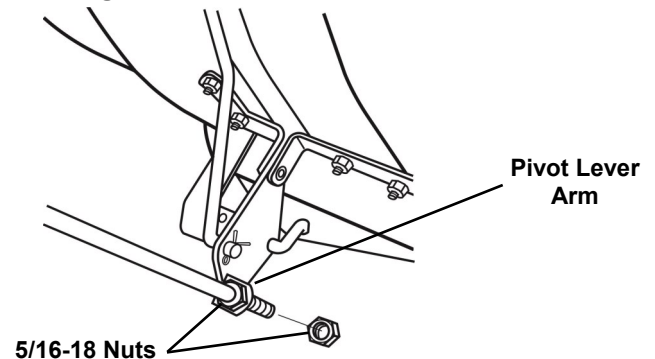

- 6) Pull the main shutoff lever to the closed position and look inside to see if the port holes are closed. If not, adjust the top and bottom nut down in small increments and recheck for closure. **CAUTION-DO NOT ADJUST THE TOP NUT TOO FAR DOWN TO PREVENT BINDING THE MECHANISM.** When the ports are closed completely, thread the bottom nut up and tighten both nuts.

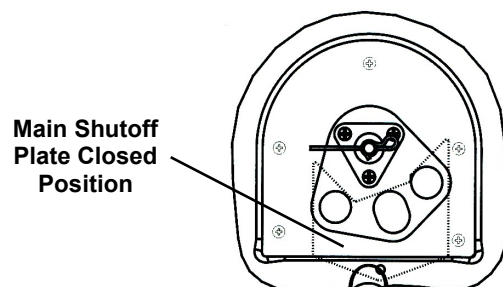

Assembly continued

7) Attach the auxiliary shutoff bracket to the left side of the handle using (2) #10-24 x 1 1/4" Phillips screws and locknuts. Slide the push-pull control into the notch on the bracket between the washer and the hex nut. Tighten the nut while taking care not to twist the cable. Secure cable to frame with a wire tie.

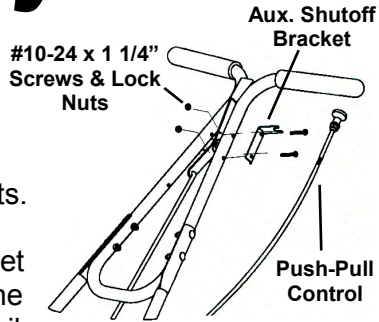

8) Attach the lever bracket to handle using (2) #10-24 x 1 1/4" Phillips screws and locknuts. Be sure bracket is aligned as shown.

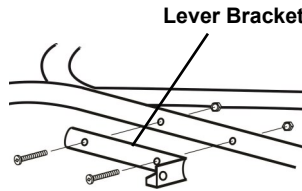

Slide the spring onto the end of the deflector rod with the form tabs as shown. Insert end of rod through the hole in the deflector bracket. Slide the rubber cap onto the end of the rod. Note: rotate the deflector rod to the up position (lever is up).

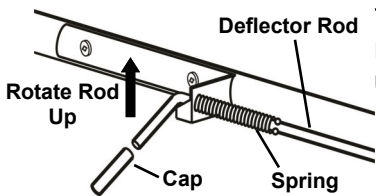

9) Insert the opposite end of the deflector control rod into the loop end of the deflector shield assembly. Secure lower end of control rod with a hitch pin. Test control rod by rotating the rod—the deflector shield should rotate up and down.

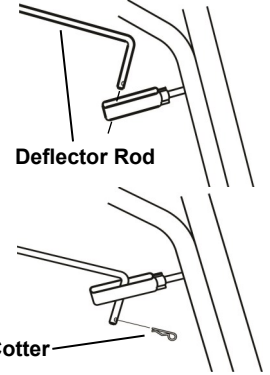

10) Using a grease gun, lubricate the grease fittings on the axle bearing housings and gear carrier. **Do not overfill.** Apply a small amount of grease to the gear teeth. Install the two gearbox cover halves and secure with the three retainor clips. Insert the screen inside the hopper and secure it with the factory installed clips.

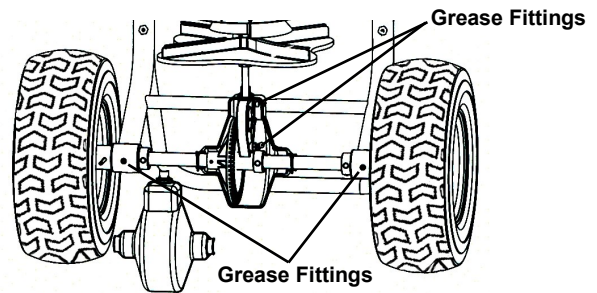

Maintenance

1) Empty the spreader after each use. Return the unused material to its original container and seal to prevent moisture-causing clumping.

2) Wash the spreader thoroughly including the impeller shaft bearing as shown and dry in a sunny or heated area. Wipe or blow off excess water to prevent corrosion. Clean all residue from rotor plate.

3) Periodically grease the axle bearing housings as indicated in assembly step #10. Turn the spreader up side down and apply a few drops of oil to the impeller shaft bearing as shown and allow oil to penetrate bearing.



4) Oil the pivot points on all the control linkage, the deflector (optional part), and the spring inside the rate control housing.

5) Periodically clean and inspect the gears by removing the gearbox cover halves. Apply a **small** amount of grease to the gear teeth for lubrication.

Apply a **small** amount of grease at the gear fittings as indicated in assembly step #10. Be sure to reinstall the gearbox cover halves prior to use.

6) Gear mesh should be checked on a regular basis during high use periods. Clearance between the axle gear and pinion gear should be minimal but not tight. If adjustment is necessary, loosen axle collar set screw and hold the gears together. Slide the axle collar against the gear carrier and tighten axle collar set screw. Spin drive wheel. Gears should run freely and smoothly.

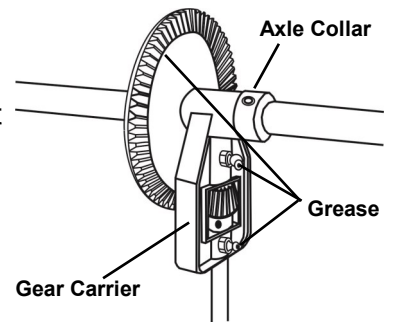

7) Maintain tire pressure at **20 psi maximum**. **Do not overfill.**

8) If the axle requires disassembly, be sure to reassemble it so the drive wheel attaches on the right hand side of spreader. Incorrect spread pattern will result if rotor plate does not rotate in a counter-clockwise direction.

Operation

HOW TO USE

1) Check product bag for rate setting (letter), cone setting (number), and swath width. The rate setting is achieved by loosening the rate control knob and sliding the rate control plate until the pointer aligns with the desired letter. The cone setting is used to control the spread pattern left and right and is adjusted by rotating the index tab on the orange helical cone to the desired number.

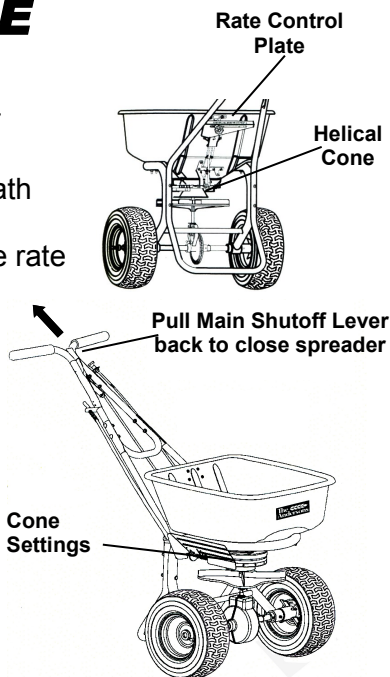

2) Pull the main shutoff lever to the closed position before filling the hopper.

3) Start rolling the spreader forward before opening the shutoff lever; close shutoff lever before stopping.

4) Hold the handle so the hopper is level. Tipping the spreader to far forward or backward will cause uneven spreading.

5) Use the swath width recommended on the bag for your model and push the spreader at 3 MPH (a brisk walking pace). Apply material in the forward direction only-not while pulling.

6) The settings given on the product label are recommended starting points. **Test rate and pattern on a small area before treating a large area. Actual application rate can vary depending on the weather, spreader condition, and walking speed.**

7) The deflector shield is used to block off the right side portion of the swath width. It should be used in the "ON" position (shield is down) together with the auxiliary shutoff in the "CLOSED" position (done by pushing the control knob forward). **IMPORTANT: Turf products will be applied excessively at the center of the swath if the auxiliary shutoff is not closed when the deflector is in use. Always remember to re-open the auxiliary shutoff (pull the control knob back) when returning to a full swath width.**

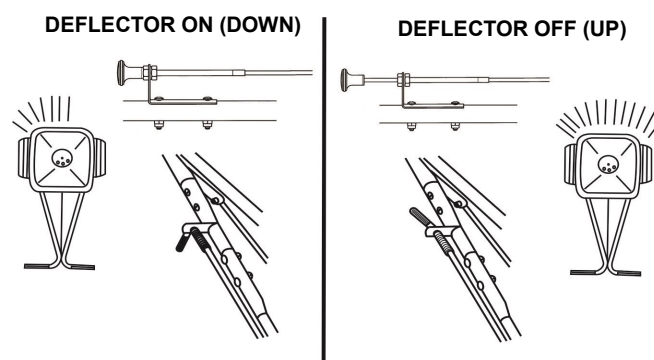

8) A hopper cover is provided with your new spreader. Use it to protect turf products inside the hopper from light rain or windy conditions during transportation.

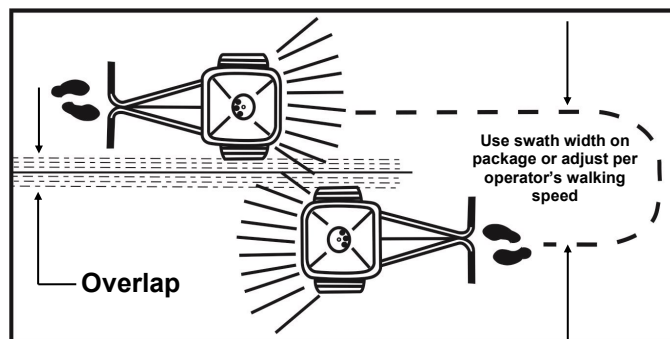

Calibration Instructions

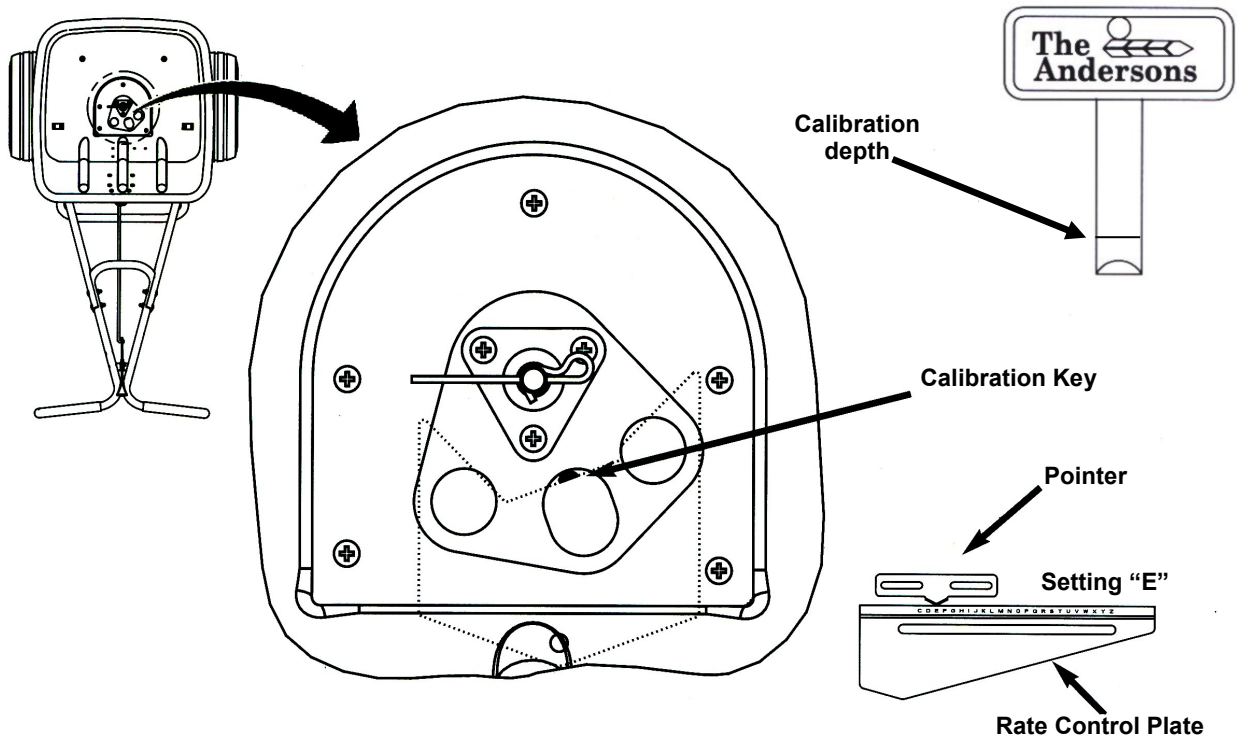

Your professional spreader has been factory calibrated. For best results, occasionally check calibration and adjust if necessary.

- 1) Pull the main shutoff lever to the closed position.
- 2) Set the rate control plate to the "E" setting.
- 3) Push the main shutoff lever to the open position.
- 4) Insert the Calibration Key vertically into the center port hole, as shown above.
- 5) If the calibration key fits snugly, the spreader is properly calibrated. If not, continue with steps 6-13.
- 6) Loosen the rate control knob and slide the rate plate all the way to the left.
- 7) Insert the calibration key as described in Step #4.
- 8) Pull the main shutoff lever to ease the shutoff plate against the calibration key. Use the main shutoff lever to hold the calibration key in place.
- 9) Slide the rate control plate to the right until it comes in contact with the protruding end of the rate control rod.
- 10) Tighten the rate control knob.
- 11) Remove the calibration key and pull the main shutoff lever to the closed position.
- 12) Loosen the nuts securing the rate control pointer and slide the pointer so that it centers on the "E" setting of the rate control plate.
- 13) Re-tighten the screws on the pointer.

Parts Diagram-Model 2000 SR _____

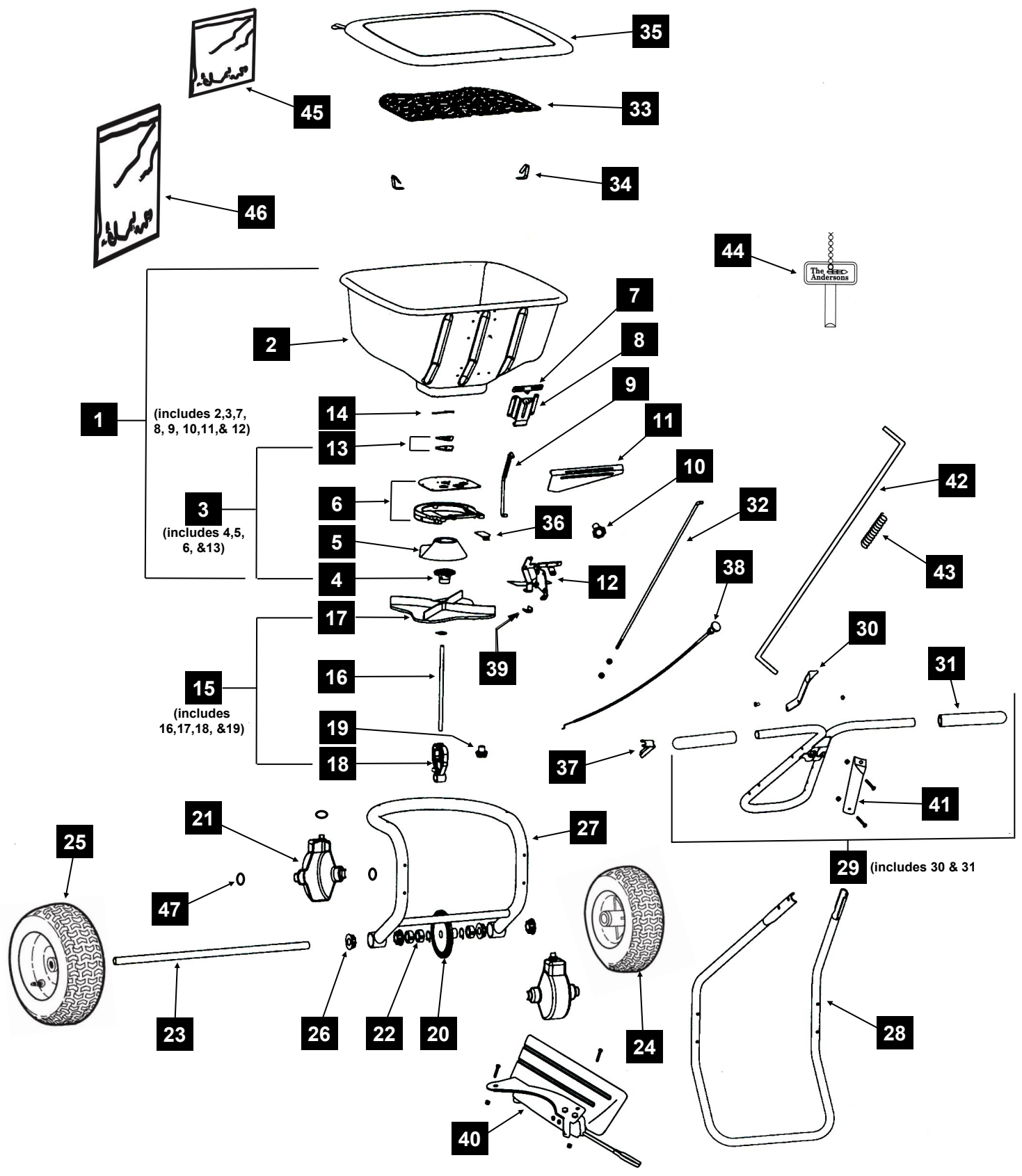

Ordering Parts

See diagram for assistance in identifying specific parts.

For parts orders, call 1-800-294-0671. (Note: Sales of parts for the Andersons spreaders are handled by EarthWay.)

IMPORTANT: When ordering replacement parts, always provide the following information:

- 1) Part number (DO NOT use key numbers when ordering parts. ALWAYS use part numbers.)
- 2) Part description
- 3) The Andersons Model 2000 SR (product code #ASP8091)

KEY #	PART DESCRIPTION	PART #
1	Hopper Assembly	791036
2	*Hopper	790115
3	*Helical Cone Assembly	780945
4	*Helical Cone Retainer/Bearing Shield	792001
5	*Helical Cone	780941
6	*Shutoff Plate Retainer/Shutoff Plate Base	792002
7	*Pointer	790342
8	*Rate Control Housing	700321
9	*Rate Control Rod Assembly	790395
10	*Rate Control Knob/Washer	792003
11	*Rate Control Plate	790331
12	*Pivot Lever/Main Shutoff Plate Assembly	790266-1
13	*Agitator-Retainer & Felt Seal	792004
14	Agitator Pin	780100
15	Rotor and Gear Carrier Assembly	780195
16	Rotor Shaft	790020
17	Rotor Plate	780191
18	Gear Carrier-Complete	780155
19	Pinion Gear	780122
20	Ring Gear	780121
21	Gearbox Cover Half (set of 2)	780110
22	Axle Collar (each)	780200
23	Axle	790015
24	Drive Wheel	790120
25	Idler Wheel	790130
26	Axle Bearing (set of 4)	790151
27	Frame Assembly (includes #26)	790046
28	Rest	790060
29	Handle Assembly (includes #30 & #31)	790076
30	Main Shutoff Lever	790215
31	Hand Grips (set of 2)	1000061
32	Main Shutoff Rod	790250
33	Hopper Screen	790141
34	Hopper Screen Clip (set of 2)	780440
35	Hopper Cover	790161
36	Auxiliary Shutoff Plate	780220
37	Auxiliary Shutoff Cable Bracket	790550
38	Auxiliary Shutoff Cable	790490
39	Auxiliary Shutoff Clamp	790560
40	Deflector Shield Assembly	1000060
41	Deflector Lever Bracket	1000059
42	Deflector Control Rod	1000053
43	Spring-Deflector Control Rod	1000052
44	Calibration Key (see calibration instructions)	15740
45	Fastener Package	1000068
46	Parts Package	15800
47	Retainer Clips-Gear Cover (set of 3)	780180

All parts and subassembly kits includes necessary fasteners and assembly instructions. * Indicates parts in Hopper Assembly.



**For More
Information
Call . . .**

1-800-225-2639
(U.S. Only)

The Andersons' toll-free
Helpline. This helpline is
provided to give you more
Information about
Andersons Turf Products.



**Or Visit Our
Website At ...**
www.andersonsturf.com

The Andersons, Inc.
480 Dussel Drive
Maumee, OH 43537 USA

Warranty

The Andersons warrants to Purchaser the following:

1. Product will be free of defects in materials and workmanship for a period of one year from date of purchase.
2. The axle gear, gear support, pinion gear, axle, and axle bearings have a limited lifetime warranty to be free of defects in materials and workmanship.
3. If the spreader is used for commercial rental the Limited Warranty shall be limited to a period of 90 days.
4. All Unit and part replacement will be performed at the reasonable discretion of The Andersons and EarthWay.
5. Labor charges are not covered and the unit need not be returned to the dealer for warranty service.
6. Proof of purchase must be supplied to The Andersons.
7. For warranty questions, contact EarthWay at 1-800-294-0671.

The Andersons sole obligation under this warranty is limited to repairing or replacing the defective part.

This warranty does not extend to any Product or parts thereof that have been allowed to corrode, subjected to misuse, neglect, accident, or modification by anyone other than The Andersons or that have been affixed to any nonstandard accessory attachment or that have been used, stored, installed, maintained operated in violation of The Andersons instructions or standard industry practice. No agent, employee or representative of The Andersons has any authority to bind The Andersons to any affirmation, representation or warranty concerning the Product and any affirmation, representation or warranty made by any agent, employee or representative shall not be enforceable by Purchaser.

THIS WARRANTY EXTENDS ONLY TO THE ORIGINAL PURCHASER AND IS EXPRESSLY IN LIEU OF ANY OTHER EXPRESS OR IMPLIED WARRANTIES, INCLUDING WITHOUT LIMITATION ANY IMPLIED WARRANTY OR MERCHANTABILITY OR FITNESS OR INTENDED USE FOR A PARTICULAR PURPOSE AND OF ANY OTHER OBLIGATION ON THE PART OF The Andersons. The Andersons SHALL NOT BE LIABLE FOR ANY INCIDENTAL, SPECIAL OR CONSEQUENTIAL LOSS, DAMAGE OR EXPENSE DIRECTLY OR INDIRECTLY ARISING FROM THE USE OF ANY OF THE PRODUCT INCLUDING, BUT NOT LIMITED TO, DAMAGE OR LOSS OF OTHER PROPERTY OR EQUIPMENT, LOSS OF PROFITS OR REVENUE, COST OF CAPITAL, COST OF PURCHASED OR REPLACEMENT GOODS, OR CLAIMS OF CUSTOMERS OF PURCHASER.



It is our first priority to improve our products' quality
and performance whenever possible.

Your comments and questions are always welcome-

Please call our Helpline: **1-800-225-2639**
(U.S. Only)

Or Visit Our Website At ...

www.andersonspro.com

**The Andersons, Inc.
480 Dussel Drive
Maumee, OH 43537**