

## Troubleshooting

- Reduced or no air flow
  - Make sure the check valve is oriented in the proper direction
  - Make sure the braided tubing is not kinked or restricted
    - Should a kinked tube or dirty membrane significantly block air flow, shut down the compressor immediately to prevent overheating
  - Check the air inlet sponge filter for clogging and clean or replace if necessary
  - Compressor not working
    - The GFCI may have tripped
    - The compressor is not receiving the correct voltage

## Replacement Parts

| Pro Air 60 Pond Aeration Kit Replacement Parts |   |
|--|---|
| No.  | Item number/description                                 |
| 1.   | 61016 - Pro Air 60 Aeration Compressor                  |
| 2.   | 61012 - 2-Way Aeration Compressor Manifold              |
| 3.   | 61002 - (1) Braided Airline Tubing - 30' Roll           |
| 4.   | 61010 - (1) 10" Rubber Membrane Aeration Diffuser       |
| 5.   | 99107 - (1) Stainless Steel Hose Clamp                  |
| 6.   | 61005 - (3) Pro Air 60 Air Inlet Sponge Filters         |
| 7.   | 61004 - Pro Air 60 Compressor Lid                       |
| 8.   | 61003 - (1) Pro Air Check Valve                         |
| 9.   | 61007 - Pro Air 60 Replacement Diaphragm (not pictured) |

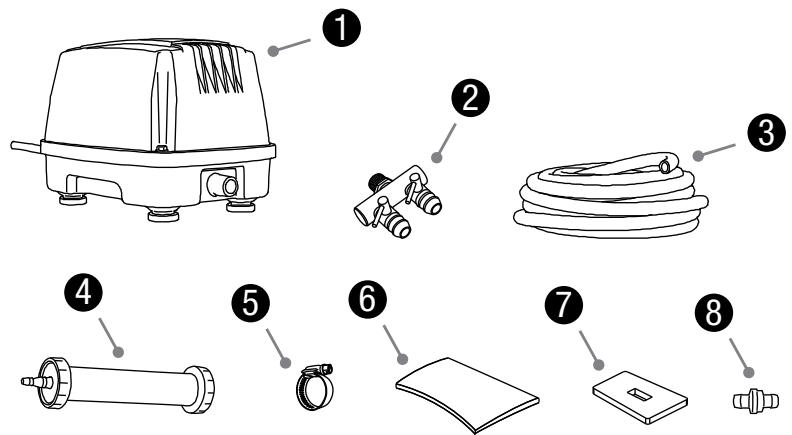

## Warranty Information

### 3 YEAR WARRANTY

The Aquascape Pro Air 60 Pond Aeration Kit is guaranteed for three years from date of purchase. Proof of purchase required. Warranty does not cover damage resulting from negligent handling, misuse, or lack of reasonable maintenance or care. Warranty is valid against defects due to material and workmanship only. The sole obligation shall be to replace the defective unit with a suitable replacement unit. Units should be checked for proper operation prior to returning as defective. No liability for loss or damage of any nature or kind, whether arising out of or from the use of the product, whether defective or not defective, is assumed by Aquascape, Inc. or its affiliates.

For more information about our company or products, please visit our website at [aquascapeinc.com](http://aquascapeinc.com) or call us at US (866) 877-6637 CAN (866) 766-3426