

INSTALLATION INSTRUCTIONS

Surface Mounted Step Lights

4501, 4901

WAC LIGHTING

CAUTION: TO PREVENT ELECTRICAL SHOCK, ENSURE ELECTRICITY HAS BEEN TURNED OFF AT THE CIRCUIT BREAKER BEFORE BEGINNING.

- Read all instructions before installing.
- System is intended for installation by a licensed electrician in accordance with the National Electrical Code (NEC) and local regulations.
- When handling the fixture, do not apply pressure to the LEDs. Hold the fixture by the base only.
- Retain installation instructions for future maintenance reference.
- Risk of electric shock. Install all luminaires 10 feet (3.05m) or more from a pool, spa, or fountain.

WARNING: All parts must be used as indicated in these instructions. This product is designed for use only with the supplied parts and/or accessories designated for use by WAC Lighting. Substitution of parts or accessories not designated for use with this product by WAC Lighting could result in personal injury or property damage, and will void the warranty. Contact an authorized dealer or the manufacturer if any parts are damaged or missing.

MAINTENANCE NOTE: Coastal conditions may cause mineral and residue build-up on the fixture. We recommend that customers in coastal areas clean all external surfaces of the fixture once every two weeks with a wet cloth.

MISE EN GARDE: Pour éviter tout choc électrique, assurez-vous que le disjoncteur soit mis hors tension avant de commencer.

- Lisez toutes les instructions avant l'installation.
- Le système doit être installé par un électricien licencié conformément au code national de l'électricité (NEC), et également aux règlements locaux.
- Lors de la manipulation du luminaire, n'appuyez pas sur les LED. Tenez-le uniquement par la base.
- Risque de choc électrique. Installez tous les luminaires de (3.05m) (10 ft.) ou plus d'une piscine, d'un spa ou d'une fontaine.

ATTENTION: Toutes les pièces doivent être utilisées comme indiqué dans ces instructions. Ce produit est conçu pour être utilisé seulement avec les pièces et/ou accessoires fournis pour être utilisés avec les produits WAC Lighting. Remplacer des pièces ou accessoires non conçus pour ce produit WAC Lighting pourrait causer des dommages corporels ou matériels et pourrait également causer l'annulation de la garantie. Veuillez contacter un revendeur autorisé ou le fabricant si des pièces manquent ou sont endommagées.

NOTE D'ENTRETIEN: Les conditions côtières peut causer une accumulation de minéraux et de résidus sur le luminaire. Nous recommandons aux clients qui résident dans les zones côtières de nettoyer toutes les surfaces externes du luminaire une fois toutes les deux semaines avec un chiffon humide.

OVERALL DIMENSIONS:

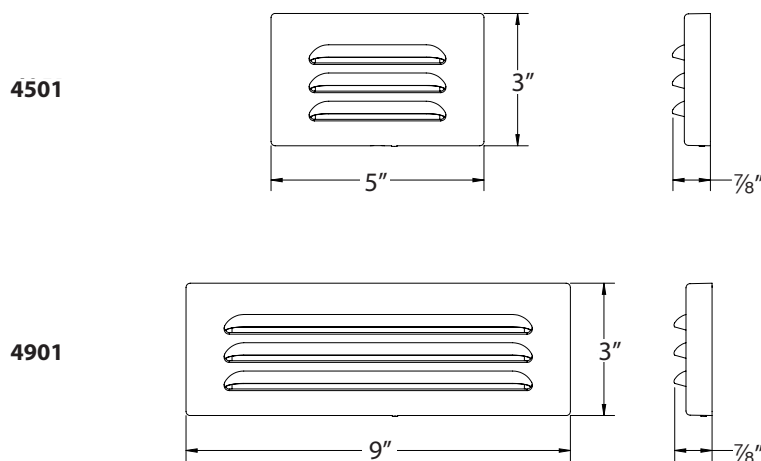

HARDWARE



Outdoor Rated Wire Nut
7EAC352401
Qty: 2 pcs

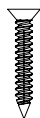

Mounting Screws
7MPF042201
Qty: 2 pcs

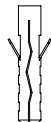

Mounting Screw Anchors
7TDD082401
Qty: 2 pcs

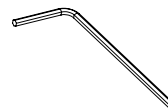

Hex Key
7MPE741601NI
Qty: 1 pcs



Hex Screw
7MPF0305K2BK
Qty: 1 pcs
(Installed in Fixture)

WAC Lighting
www.waclighting.com
Phone (800) 526.2588 • Fax (800) 526.2585

Headquarters/Eastern Distribution Center
44 Harbor Park Drive • Port Washington, NY 11050
Phone (516) 515.5000 • Fax (516) 515.5050

Western Distribution Center
1750 Archibald Ave • Ontario, CA 91761
Phone (800) 526.2588 • Fax (800) 526.2585

INSTALLATION INSTRUCTIONS

Surface Mounted Step Lights

4501, 4901

WAC LIGHTING

INSTALLATION: (NO BACK JUNCTION BOX REQUIRED)

1. Using Fixture Light Engine Assembly (**Fig.3**), mark center point of thru hole that will be drilled to feed lead wire from fixture through wall or step (**Fig. 4**). Lead wire is located on center of fixture.
2. Where center point of thru hole for lead wire is marked drill a 1" hole through surface.
3. Using Fixture Light Engine Assembly or dimensions provided (**Fig. 5**), mark the location of the two mounting holes.
4. Install plastic wall anchors for brick, block, stone or concrete at location of two mounting holes (**Fig.6**). (This is not required for wood applications.) Secure fixture light engine assembly to wall or step.
5. Connect the fixture wires to landscape wires connected to your transformer using the provided outdoor rated wire nuts (**Fig.7**).
6. Snap Fixture Face Plate onto Fixture Light Engine Assembly, lock the face plate by the hex screw with provided hex key (**Fig. 3**).
7. Provide 12V power to fixture and check for proper installation.

FIG. 3

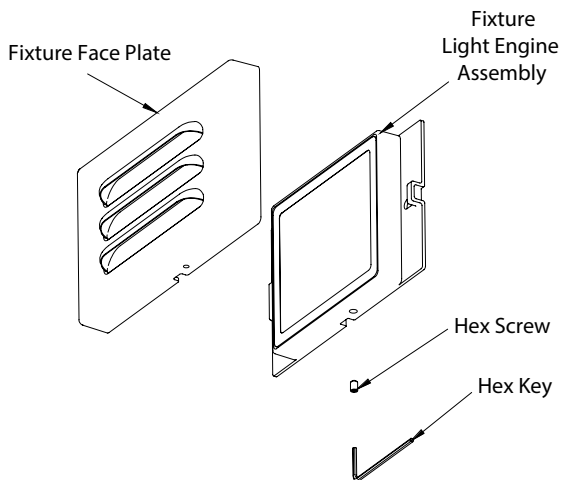
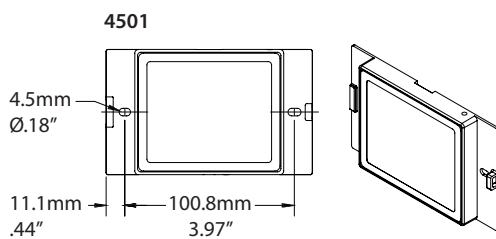

FIG. 5



4901

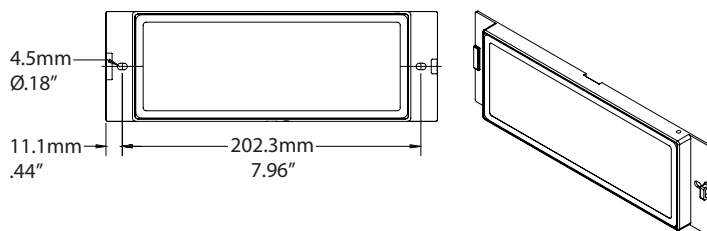

FIG. 4

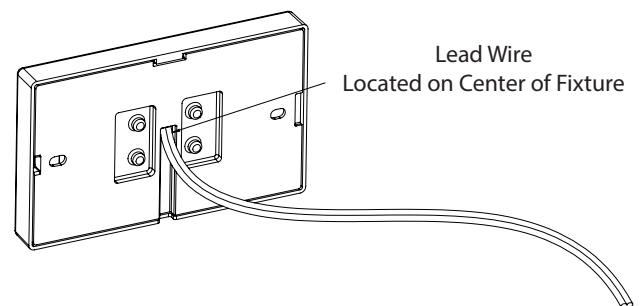

FIG. 6

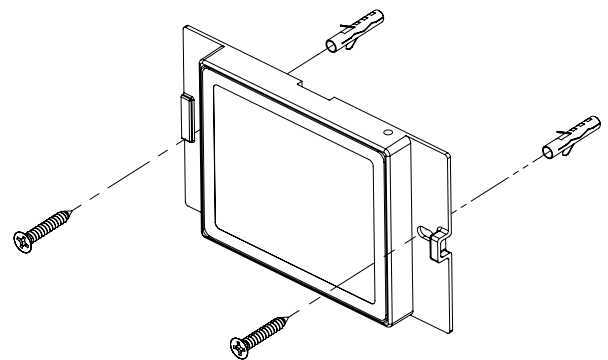
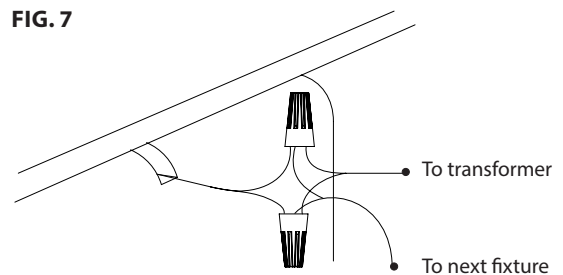

FIG. 7



WAC Lighting
www.waclighting.com
Phone (800) 526.2588 • Fax (800) 526.2585

Headquarters/Eastern Distribution Center
44 Harbor Park Drive • Port Washington, NY 11050
Phone (516) 515.5000 • Fax (516) 515.5050

Western Distribution Center
1750 Archibald Ave • Ontario, CA 91761
Phone (800) 526.2588 • Fax (800) 526.2585