

Atrium Grates

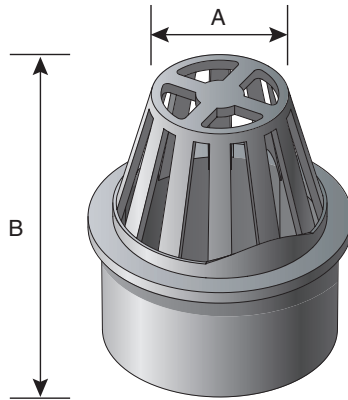

Dimension Key

- A: Diameter at top of atrium
- B: Height
- C: Grate opening width
- D: Open surface area
- E: GPM
- F: Load rating
- G: Weight
- H: Fits

| Part Number | A | B | C | D | E | F | G | H |
|-------------|-------|---------|-----|--------------|-------|-----|-----|---|
| 270 | 1 3/8 | 2 7/8 | 1/4 | 4 Sq. in | 5.24 | N/A | .1 | 2" Sch 40 fittings |
| 70 | 2 1/4 | 3 11/16 | 1/4 | 9.5 Sq. in | 12.45 | N/A | .25 | 3" S&D pipe, 3" S&D fittings, 3" corrugated pipe, 3" triple wall pipe |
| 72 | 2 1/4 | 3 11/16 | 1/4 | 9.5 Sq. in | 12.45 | N/A | .25 | 3" S&D pipe, 3" S&D fittings, 3" corrugated pipe, 3" triple wall pipe |
| 74 | 2 1/4 | 3 11/16 | 1/4 | 9.5 Sq. in | 12.45 | N/A | .25 | 3" S&D pipe, 3" S&D fittings, 3" corrugated pipe, 3" triple wall pipe |
| 74S | 2 1/4 | 3 11/16 | 1/4 | 9.5 Sq. in | 12.45 | N/A | .25 | 3" S&D pipe, 3" S&D fittings, 3" corrugated pipe, 3" triple wall pipe |
| 75 | 2 3/4 | 4 7/16 | 1/4 | 14.50 Sq. in | 19.00 | N/A | .30 | 4" S&D pipe, 4" S&D fittings, 4" corrugated pipe, 4" triple wall pipe |
| 76 | 2 3/4 | 4 7/16 | 1/4 | 14.50 Sq. in | 19.00 | N/A | .30 | 4" S&D pipe, 4" S&D fittings, 4" corrugated pipe, 4" triple wall pipe |
| 78 | 2 3/4 | 4 7/16 | 1/4 | 14.50 Sq. in | 19.00 | N/A | .30 | 4" S&D pipe, 4" S&D fittings, 4" corrugated pipe, 4" triple wall pipe |
| 78S | 2 3/4 | 4 7/16 | 1/4 | 14.50 Sq. in | 19.00 | N/A | .30 | 4" S&D pipe, 4" S&D fittings, 4" corrugated pipe, 4" triple wall pipe |
| 80 | 3 7/8 | 5 3/4 | 1/4 | 25.5 Sq. in. | 33.41 | N/A | .7 | Spee-D basin, 6" S&D pipe, 6" S&D fittings, 6" corrugated pipe |
| 81 | 3 7/8 | 5 3/4 | 1/4 | 25.5 Sq. in. | 33.41 | N/A | .7 | Spee-D basin, 6" S&D pipe, 6" S&D fittings, 6" corrugated pipe |
| 90 | 3 7/8 | 5 3/4 | 1/4 | 25.5 Sq. in. | 33.41 | N/A | .7 | Spee-D basin, 6" S&D pipe, 6" S&D fittings, 6" corrugated pipe |
| 90S | 3 7/8 | 5 3/4 | 1/4 | 25.5 Sq. in. | 33.41 | N/A | .7 | Spee-D basin, 6" S&D pipe, 6" S&D fittings, 6" corrugated pipe |