

PEB and PESB Series Valves

Durable valves. Patented technology.

Pressure surges? Effluent water? Clogging debris? No problem. PEB and PESB Series valves offer long life and efficient, trouble-free performance—even under harsh conditions. Constructed of heavy-duty, glass-filled nylon, these valves resist clogging. And the PESB model features a patented scrubber to actively fight dirt, debris and particles.

Features

- Durable glass-filled nylon construction for long life and heavy-duty performance at 200 psi (13,80 bars) pressure.
- Stainless steel studs molded into the body. Bonnet can be attached and removed more easily and more often without damaging threads.
- One-piece solenoid design with captured plunger and spring for easy servicing. Prevents loss of parts during field service.
- External bleed does not allow debris to go through the solenoid ports when system is flushed.
- Internal bleed operates the valve without allowing water into the valve box; allows pressure regulator to be adjusted without turning on the valve at the controller first.
- Low flow operating capability (0.25 gpm; 0,06 m³/h; 0,02 l/s) for a wide range of applications. For flows below 3 gpm (0,75 m³/h; 0,21 l/s) or any Xerigation® application, install Rain Bird Y filter upstream.
- Slow closing to prevent water hammer and subsequent system damage.
- **PESB only:** Nylon scrubber scrapes its stainless steel screen clean to break down grit and plant material. Prevents debris build-up and clogging.

Options (order separately)

- Accommodate optional, field installed PRS-D pressure regulating module to ensure optimum sprinkler performance.
- Optional purple flow control handles for non-potable water applications PEB-NP-HAN1 (1") PEB-NP-HAN2 (1½" and 2")
- Accepts latching solenoid for use with Rain Bird battery-operated controllers up to 150 psi (10,35 bars).

Operating Range

- Pressure: 20 to 200 psi (1,38 to 13,80 Bars)
- Flow: 0.25 to 200 gpm (0,06 to 45,40 m³/h; 0,02 to 12,60 l/s)

- Flow with PRS-D: 5 to 200 gpm (1,14 to 45,40 m³/h; 0,32 to 12,60 l/s)
- Temperature: up to 150° F (66° C)

Electrical Specifications

- Power: 24 VAC 50/60 cycle solenoid
- Inrush current: 0.41 A (9.9 VA)
- Holding current: 0.28 A (6.72 VA)

Models

- 100PEB and 100PESB 1" (26/34)
- 150PEB and 150PESB 1½" (40/49)
- 200PEB and 200PESB 2" (50/60)

BSP threads available, specify when ordering.

Pressure Loss (psi)

gpm	100 - 1"	150 - 1½"	200 - 2"
0.25	0.8	-	-
0.5	1.0	-	-
1	1.3	-	-
5	1.7	-	-
10	1.8	-	-
20	2.9	4.0	-
30	5.6	3.6	-
40	10.0	2.7	-
50	15.6	2.4	3.1
75	-	4.2	2.9
100	-	8.5	3.9
125	-	14.6	6.8
150	-	21.2	10.0
175	-	-	13.6
200	-	-	17.5

Pressure Loss (bars)

m ³ /h	l/s	100 - 1"	150 - 1½"	200 - 2"
0.06	0.02	0.05	-	-
1	0.28	0.11	-	-
2	0.56	0.12	-	-
3	0.83	0.15	-	-
4	1.11	0.18	-	-
5	1.39	0.24	0.27	-
6	1.67	0.32	0.26	-
7	1.94	0.41	0.24	-
8	2.22	0.54	0.21	-
9	2.50	0.68	0.19	-
10	2.78	0.84	0.18	-
12	3.33	-	0.18	0.21
14	3.89	-	0.22	0.21
16	4.44	-	0.26	0.20
22	6.11	-	0.55	0.26
28	7.78	-	0.98	0.46
34	9.45	-	1.46	0.69
40	11.11	-	-	0.95
45	12.50	-	-	1.18

Notes

- 1) Loss values are with flow control fully open.
- 2) PRS-D module recommended for use below bold line.

Recommendations

- 1) Rain Bird recommends flow rates in the supply line not to exceed 7.5 ft./sec. (2.29 m/s) in order to reduce the effects of water hammer.
- 2) For flows below 5 gpm (1,14 m³/h; 0,32 l/s), Rain Bird recommends use of upstream filtration to prevent debris from collecting below the diaphragm.
- 3) For flows below 10 gpm (2,27 m³/h; 0,63 l/s) Rain Bird recommends the flow control stem be turned down two full turns from the fully open position.

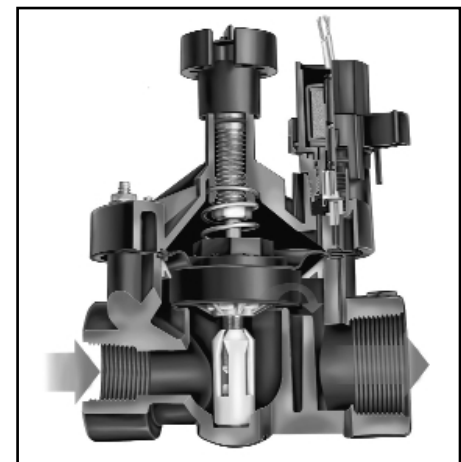

Dimensions

Size	Height	Length	Width
100	6½" (16,5 cm)	4" (10,2 cm)	4" (10,2 cm)
150	8" (20,3 cm)	6" (15,2 cm)	6" (15,2 cm)
200	8" (20,3 cm)	6" (15,2 cm)	6" (15,2 cm)

Note: The PRS-D option adds 2" (5,1 cm) to valve height.

How to Specify

100-PEB-PRS-D

Size	Model	Optional Feature
100: 1"	PEB	PRS-D: pressure regulating module
150: 1½"	PESB: scrubber model	
200: 2"		

Note: Valve and PRS-D module must be ordered separately.



Specifications

The electric remote control valve shall be a normally closed 24 VAC 50/60 cycle solenoid actuated globe pattern design. The valve pressure rating shall not be less than 200 psi (13,80 bars). The valve shall have the following characteristics (circle one):

Flow rate: _____ gpm m³/h l/s

Pressure loss not to exceed: _____ psi bars

The valve body and bonnet shall be constructed of heavy-duty glass-filled UV-resistant nylon and have stainless steel studs and flange nuts; diaphragm shall be of nylon reinforced nitrile rubber.

The valve shall have both internal and external manual open/close control (internal and external bleed) to manually open and close the valve without electrically energizing the solenoid. The valve's internal bleed shall prevent flooding of the valve box.

The valve shall house a fully-encapsulated, one-piece solenoid. The solenoid shall have a captured plunger with a removable retainer for easy servicing and a leverage handle for easy turning. This 24 VAC 50/60 Hz solenoid shall open with 19.6 volt minimum at 200 psi (13,80 bars). At 24 VAC, average inrush current shall not exceed 0.41 amps. Average holding current shall not exceed 0.23 amps.

The valve shall have a brass flow control stem for accurate manual regulation and/or shut-off of outlet flow. The valve must open or close in less than 1 minute at 200 psi (13,80 bars), and less than 30 seconds at 20 psi (1,38 bars).

The PESB valve shall have a self-cleaning stainless steel screen designed for use in dirty water applications.

The valve construction shall be such as to provide for all internal parts to be removable from the top of the valve without disturbing the valve installation.

Optional Feature Specification

PRS-D Pressure Regulating Module:

100PEB-PRS-D 100PESB-PRS-D

150PEB-PRS-D 150PESB-PRS-D

200PEB-PRS-D 200PESB-PRS-D

When so indicated on the design, the 1", 1½" and 2" electric remote control plastic valves shall have a pressure regulating module (PRS-D) capable of regulating outlet pressure between 15 and 100 psi (±3 psi) (1,04 and 6,90 bars (±0,21 bars)).

The PRS-D module shall have an adjusting screw for setting pressure and Schrader valve connection for monitoring pressure. The pressure shall be adjustable from the PRS-D when the valve is internally manually bled or electrically activated.

Non-Potable Flow Control Handle

PEB-NP-HAN1 - Fits 1"

PEB-NP-HAN2 - Fits 1½" and 2"

When so indicated on the design, the valve shall have a purple flow control handle to indicate to the user that non-potable water is being used. There shall be no difference between the black and purple handles except for the color.

The valve shall be as manufactured by Rain Bird Sprinkler Mfg. Corp., Glendora, California.

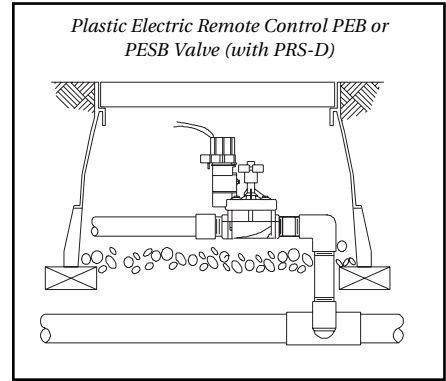

Rain Bird Corporation

Contractor Division

970 West Sierra Madre Avenue, Azusa, CA 91702

Phone: (626) 963-9311 Fax: (626) 812-3411

Rain Bird Corporation

Commercial Division

6991 East Southpoint Road, Tucson, AZ 85706

Phone: (520) 741-6100 Fax: (520) 741-6522

Rain Bird International, Inc.

145 North Grand Avenue, Glendora, CA 91741

Phone: (626) 963-9311 Fax: (626) 963-4287

Rain Bird Technical Service

(800) 247-3782 (U.S. only)

www.rainbird.com

Rain Bird. Conserving More Than Water.

© Registered trademark of Rain Bird Sprinkler Mfg. Corp.

© 2001 Rain Bird Sprinkler Mfg. Corp. 3/01

D38950M