

GB, EFB-CP, and EFB-CP-R Series Valves

Classic Hardware. Classic Performance.

Electric remote control valves don't come any better than GB and EFB-CP Series red brass valves. Looking for heavy duty performance in clean water applications? Choose the GB! Need a contamination-proof, self-flushing screen that cleans itself and resists debris build-up in dirty water? The EFB-CP's the one! Now also available in a reclaimed water valve configuration, the EFB-CP-R is designed to handle chlorine and other harsh chemicals found in reclaimed water systems. EFB-CP-R series valves offer long life and superior performance in high pressure applications.

Features

- Red brass body and bonnet for longer life and more rugged performance at 200 psi (13,80 bar).
- Reverse flow feature ensures valve will fail in the closed position if a tear or rip in the diaphragm occurs. Prevents flooding, water waste and landscape damage.
- Fluid resistor slows flow through the solenoid, reducing closing speed and preventing water hammer and system damage.
- One-piece solenoid design with captured plunger and spring prevents loss of parts.
- Low power requirement allows for longer wire runs without increased wire gauge size.
- Manual internal and external bleed.
- Adjustable flow control.
- Contamination-proof, self-flushing nylon (EFB-CP) or stainless steel (EFB-CP-R) screen resists debris build-up. Water flow continuously flushes the screen, dislodging particles and debris before they can accumulate and clog the filter.

Options (order separately)

- Accommodates optional, field installed PRS-D pressure regulating module.
- Optional purple flow control handle for easy identification of non-potable water system. (EFB-GB-NP-HAN)
- Accepts latching solenoid for use with Rain Bird battery-operated controllers up to 150 psi (10,35 bar).

Operating Range

- Pressure: 15 to 200 psi (1,04 to 13,80 bar)
- Flow with/without PRS-D: 5 to 200 gpm (1,14 to 45,40 m³/h; 0,32 to 12,60 l/s)
- Temperature: up to 150° F (66° C)

Electrical Specifications

- Power: 24 VAC 50/60 cycle solenoid
- Inrush current: 0.41 A (9.84 VA)
- Holding current: 0.28 A (6.72 VA)

Models

- 100GB: 1" (26/34)
- 125GB: 1 1/4" (33/42)
- 150GB: 1 1/2" (40/49)
- 200GB: 2" (50/60)
- 100EFB-CP: 1" (26/34)*
- 125EFB-CP: 1 1/4" (33/42)
- 150EFB-CP: 1 1/2" (40/49)*
- 200EFB-CP: 2" (50/60)*
- 100EFB-CP-R: 1" (26/34)
- 150EFB-CP-R: 1 1/2" (40/49)
- 200EFB-CP-R: 2" (50/60)

*BSP threads available; specify when ordering.

Pressure Loss (psi)

| gpm | GB | | | | EFB-CP | | | | EFB-CP-R | | | |
|-----|-----|------|------|------|--------|------|------|------|----------|------|------|--|
| | 100 | 125 | 150 | 200 | 100 | 125 | 150 | 200 | 100 | 150 | 200 | |
| 5 | 0.4 | - | - | - | 0.2 | - | - | - | 0.2 | - | - | |
| 10 | 0.8 | - | - | - | 0.7 | - | - | - | 0.6 | - | - | |
| 15 | 1.2 | - | - | - | 1.2 | - | - | - | 1.2 | - | - | |
| 20 | 2.1 | 1.4 | 2.3 | 0.6 | 2.1 | 1.4 | 2.3 | 0.5 | 2.2 | 0.6 | 0.4 | |
| 30 | 5 | 2.3 | 2.9 | 0.7 | 5 | 2.3 | 2.9 | 0.6 | 4.9 | 1.3 | 0.5 | |
| 40 | 8.2 | 4.1 | 2 | 0.9 | 8.2 | 4.1 | 2 | 0.8 | 8.6 | 2.2 | 0.7 | |
| 50 | 13 | 6.8 | 3.3 | 1.1 | 13 | 6.8 | 3.3 | 1.1 | 13.4 | 3.4 | 1.0 | |
| 60 | - | 9.8 | 4.6 | 1.7 | - | 9.8 | 4.6 | 1.8 | - | 4.9 | 1.5 | |
| 80 | - | 16.5 | 7.5 | 2.6 | - | 16.5 | 7.5 | 2.4 | - | 8.5 | 2.5 | |
| 100 | - | - | 11.8 | 3.9 | - | - | 11.8 | 3.8 | - | 13.2 | 3.9 | |
| 120 | - | - | 16.6 | 5.9 | - | - | 16.6 | 5.9 | - | 18.6 | 5.8 | |
| 140 | - | - | - | 7.8 | - | - | - | 7.8 | - | - | 7.3 | |
| 160 | - | - | - | 10 | - | - | - | 10 | - | - | 9.2 | |
| 180 | - | - | - | 12.4 | - | - | - | 12.5 | - | - | 11.8 | |
| 200 | - | - | - | 15.1 | - | - | - | 15.8 | - | - | 14.5 | |

Pressure Loss (bars)

| m ³ /h | l/s | GB | | | | EFB-CP | | | | EFB-CP-R | | | |
|-------------------|-------|------|------|------|------|--------|------|------|------|----------|------|------|--|
| | | 100 | 125 | 150 | 200 | 100 | 125 | 150 | 200 | 100 | 150 | 200 | |
| 1 | 0.32 | 0.13 | - | - | - | 0.18 | - | - | - | 0.01 | - | - | |
| 2 | 0.56 | 0.17 | - | - | - | 0.23 | - | - | - | 0.04 | - | - | |
| 3 | 0.83 | 0.20 | - | - | - | 0.28 | - | - | - | 0.08 | - | - | |
| 4 | 1.11 | 0.24 | - | - | - | 0.37 | - | - | - | 0.15 | 0.04 | 0.03 | |
| 5 | 1.39 | 0.30 | 0.17 | 0.22 | 0.09 | 0.49 | 0.18 | 0.21 | 0.08 | 0.25 | 0.07 | 0.03 | |
| 6 | 1.67 | 0.35 | 0.18 | 0.23 | 0.09 | 0.62 | 0.19 | 0.23 | 0.09 | 0.33 | 0.09 | 0.03 | |
| 7 | 1.94 | 0.42 | 0.20 | 0.24 | 0.10 | 0.74 | 0.21 | 0.25 | 0.09 | 0.47 | 0.12 | 0.04 | |
| 8 | 2.22 | 0.54 | 0.27 | 0.23 | 0.10 | 0.80 | 0.27 | 0.24 | 0.09 | 0.59 | 0.15 | 0.05 | |
| 9 | 2.50 | 0.66 | 0.34 | 0.23 | 0.10 | 0.86 | 0.33 | 0.23 | 0.10 | 0.75 | 0.19 | 0.06 | |
| 10 | 2.78 | 0.83 | 0.42 | 0.23 | 0.10 | 1.05 | 0.42 | 0.25 | 0.10 | 0.91 | 0.23 | 0.07 | |
| 12 | 3.33 | 1.17 | 0.59 | 0.25 | 0.11 | 1.46 | 0.60 | 0.29 | 0.10 | 1.25 | 0.33 | 0.10 | |
| 14 | 3.89 | - | 0.78 | 0.33 | 0.13 | - | 0.82 | 0.37 | 0.12 | - | 0.46 | 0.13 | |
| 16 | 4.44 | - | 1.02 | 0.42 | 0.15 | - | 1.08 | 0.47 | 0.15 | - | 0.58 | 0.17 | |
| 22 | 6.11 | - | - | 0.72 | 0.25 | - | 1.08 | 0.47 | 0.24 | - | 1.09 | 0.34 | |
| 28 | 7.77 | - | - | 1.23 | 0.43 | - | - | 0.80 | 0.42 | - | 1.62 | 0.50 | |
| 34 | 9.44 | - | - | - | 0.64 | - | - | 1.36 | 0.63 | - | - | 0.71 | |
| 40 | 11.10 | - | - | - | 0.87 | - | - | - | 0.87 | - | - | 0.99 | |
| 45 | 12.60 | - | - | - | 1.14 | - | - | - | 1.10 | - | - | 1.22 | |

Notes

- 1) Loss values are with flow control fully open.
- 2) PRS-D module recommended for all flow ranges.

Recommendations

- 1) Rain Bird recommends flow rates in the supply line not to exceed 7.5 ft./sec. (2,29 m/s) in order to reduce the effects of water hammer.
- 2) For flows below 5 gpm (1,14 m³/h; 0,32 l/s), Rain Bird recommends use of upstream filtration to prevent debris from collecting below the diaphragm.
- 3) For flows below 10 gpm (2,27 m³/h; 0,63 l/s) Rain Bird recommends the flow control stem be turned down two full turns from the fully open position.

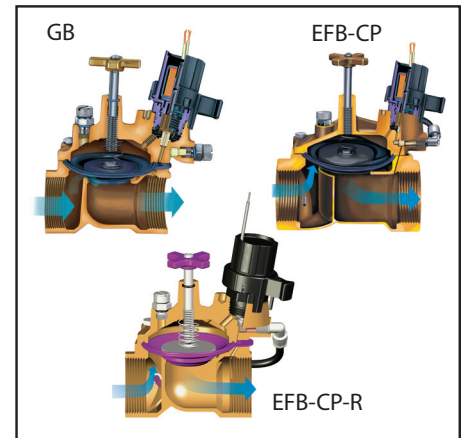
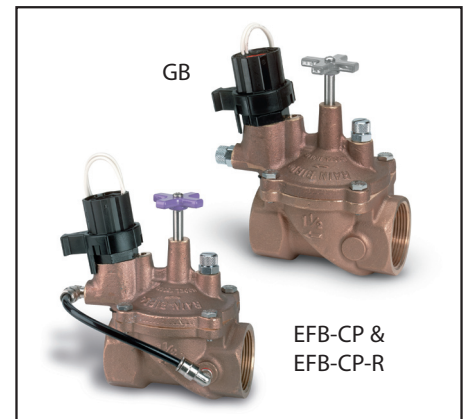

Dimensions

| Size | Height | Length | Width |
|-------------|------------------|------------------|------------------|
| 100GB | 6" (15,2 cm) | 4 1/2" (11,4 cm) | 2 1/4" (5,7 cm) |
| 125GB | 5 1/2" (14,6 cm) | 5" (12,7 cm) | 3" (7,6 cm) |
| 150GB | 6 1/2" (16,5 cm) | 5 1/2" (14 cm) | 4" (10,2 cm) |
| 200GB | 7" (17,8 cm) | 6 1/4" (17,1 cm) | 5 1/4" (13,3 cm) |
| 100EFB-CP | 6" (15,2 cm) | 4 1/2" (11,4 cm) | 3 1/4" (8,3 cm) |
| 125EFB-CP | 5 1/2" (14,6 cm) | 5" (12,7 cm) | 3 3/4" (8,3 cm) |
| 150EFB-CP | 6 1/2" (16,5 cm) | 5 1/2" (14 cm) | 4 1/2" (11,4 cm) |
| 200EFB-CP | 7" (17,8 cm) | 6 1/4" (17,1 cm) | 5 1/4" (14,6 cm) |
| 100EFB-CP-R | 6" (15,2 cm) | 4 1/2" (11,4 cm) | 3 1/4" (8,3 cm) |
| 150EFB-CP-R | 6 1/2" (16,5 cm) | 5 1/2" (14 cm) | 4 1/2" (11,4 cm) |
| 200EFB-CP-R | 7" (17,8 cm) | 6 1/4" (17,1 cm) | 5 1/4" (14,6 cm) |

Note: The PRS-D option adds 2" (5,1 cm) to valve height.

How to Specify/Order

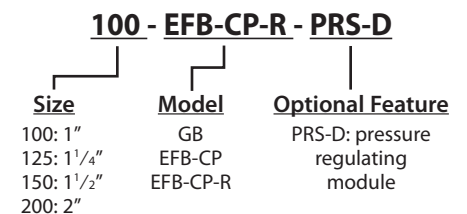

Note: Valve and PRS-D module must be ordered separately.



Specifications

The electric remote control valve shall be a normally closed 24 VAC 50/60 cycle solenoid actuated globe pattern with a balanced pressure diaphragm design. The valve pressure rating shall not be less than 200 psi (13,80 bar). The valve shall have the following characteristics (circle one):

Flow rate: _____ gpm m³/h l/s

Pressure loss not to exceed: _____ psi bar

The valve body and bonnet shall be constructed of heavy cast red brass; diaphragm shall be of nylon reinforced nitrile rubber (GB & EFB-CP) or nylon reinforced EPDM rubber (EFB-CP-R). All other internal parts shall be made of bronze, brass, and stainless steel to ensure corrosion resistance.

The valve shall have both internal and external manual open/close control (internal and external bleed) for manually opening and closing the valve without electrically energizing the solenoid. The valve shall have internal manual bleed to prevent flooding of the valve box.

The valve shall house a fully-encapsulated, one-piece solenoid. The solenoid shall have a captured plunger with a removable retainer for easy servicing and a leverage handle for easy turning. This 24 VAC 50/60 Hz solenoid shall open with 19.6 VAC minimum at 200 psi (13,80 bar). At 24 VAC average inrush current, it shall not exceed 0.41 amps. Average holding current shall not exceed 0.28 amps.

The valve shall have a stainless steel flow control stem and cross handle for regulating or shutting off the flow of water. The valve must open or close in less than one minute at 200 psi (13,80 bar), and less than 30 seconds at 20 psi (1,38 bar).

The valve construction shall be such as to provide for all internal parts to be removable

from the top of the valve without disturbing the valve installation.

GB only: The valve shall have a control port filter screen to filter out grit and prevent clogging of hydraulic control ports.

EFB-CP only: The valve shall have a contamination proof (CP) self-flushing nylon screen located at the valve inlet to filter out grit and prevent clogging of hydraulic control ports and assure reliable operation.

EFB-CP-R only: The valve shall have a contamination proof (CP) self-flushing stainless steel screen located at the valve inlet to filter out grit and prevent clogging of hydraulic control ports and assure reliable operation. The valve shall also have a purple flow control handle and chlorine resistant diaphragm.

Optional Feature Specification

When so indicated on the design, the 1", 1 1/2", 1 1/4", and 2" electric remote control valves shall have a pressure regulating module (PRS-D) capable of regulating outlet pressure between 15 and 100 psi (±3 psi) (1,04 and 6,90 bar (±0,21 bar)).

The PRS-D module shall have an adjusting knob for setting pressure and Schrader valve connection for monitoring pressure. Pressure shall be adjustable from the PRS-D when the valve is internally manually bled or electrically activated.

Non-Potable Flow Control Handle EFB-GB-NP-HAN

When so indicated on the design, the valve shall have a purple flow control handle to indicate to the user that non-potable water is being used. There shall be no difference between the brass and purple handles except for the color.

Brass Electric Remote Control GB Valve

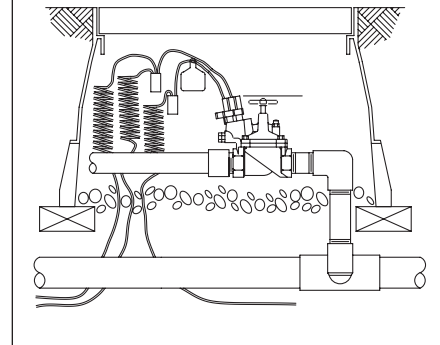

Brass Electric Remote Control
EFB-CP & EFB-CP-R Valve

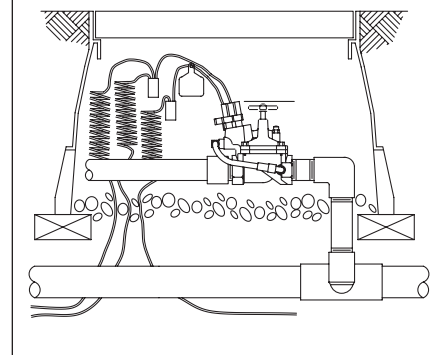

The valve shall be as manufactured by Rain Bird Corporation, Glendora, California.

Rain Bird Corporation

6991 E. Southpoint Road, Tucson, AZ, 85706, U.S.A.
Phone: (520) 741-6100 Fax: (520) 741-6522

Rain Bird Corporation

970 W. Sierra Madre Avenue, Azusa, CA, 91702, U.S.A.
Phone: (626) 812-3400 Fax: (626) 812-3411

Rain Bird International, Inc.

P.O. Box 37, Glendora, CA, 91740-0037, U.S.A.
Phone: (626) 963-9311 Fax: (626) 852-7343

Technical Service and Support

(800) RAINBIRD (U.S. and Canada only)

Specification Hotline

(800) 458-3005 (U.S. and Canada only)

www.rainbird.com

The Intelligent Use of Water™ – Visit www.rainbird.com to learn about our efforts