

# SPYKER

THE SPREADER PEOPLE

*spread with confidence*

**Spreading Chart  
Operation Guide  
Service Manual  
Parts List**

**For Models:  
120, 220**



*It's the spread that counts*

**P.O. Box 7  
140 Mill Street  
Urbana, IN  
46990 USA**



**1-800-972-6130  
Fax: 260-774-3416**

**For Quick and Easy Assembly - First Read Entire Procedure  
Then Follow Carefully The Step by Step Instructions**

## *Tools you will need:*

Medium Sized Flathead Screwdriver, Pliers  
and 7/16" & 3/8" wrenches

## *Parts you will use:*

### Parts for Models: 120

- (1) Lever Control Tube Brace
- (1) Bolt - Control Brace to Hopper 1/4-20 x 3/4"
- (3) Bolt - Control Brace to Control Tube & Levers to Control Tube 1/4-20 x 1 1/2"
- (2) Bolt - Lever Control Tube to Hopper
- (6) Lock Nut
- (3) Nylon Washer
- (1) Plastic End Cap / Control Tube End
- (1) Hex Key for Spinner Shaft Coupler
- (2) Hopper Bottom Bearing "for Replacement"

### Parts for Models: 220

- (6) Bolt - Hopper to Frame & Control Tube to Hopper, 1/4-20 x 2"
- (2) Bolt - Deflector Shield to Frame 1/4-20 x 13/4"
- (1) Bolt - Control Brace to Hopper 1/4-20 x 3/4"
- (3) Bolt - On/Off Levers to Control Tube & Brace to Control Tube 1/4-20 x 1 1/2"
- (12) Lock Nut
- (1) Lever Control Brace
- (1) Spinner Clip
- (1) Spinner Shaft
- (1) Spinner / Grey Plastic
- (1) Mulch Spinner
- (1) Hex Key for Spinner Shaft Coupler
- (2) Hopper Bottom Bearing "for Replacement"
- (9) Nylon Washer
- (1) Plastic End Cap / Control Tube
- (1) Small Parts Bag with Agitator & Felt Washer for use with grass Seed
- (2) Set Screw 1/4-20 x 3/8" Allen for Spinner Shaft Coupler
- (2) Plastic End Cap / Frame
- (1) Coupler for New Motor Shaft

1.

Insert Bump Bar (1) into Frame (2), but do not bolt together at this time.

**\* For model 120, skip to step 4**



2.

Place Hopper Assembly onto Frame (2). Note: The Rate Gate Control Lever (4) & the Accuway® Control Lever (5) go under the frame cross brace.



3.

Bolt Hopper Assembly to frame (2) using 4 bolts (6) with 4 nylon washers (7) and 4 nuts (8).



4.

Attach Lever Control Bar (9) to Hopper Assembly with 2 bolts (10) and 2 nylon washers (7) and 2 nuts (8).



5.

Attach the Lever Control Brace (11) to the Lever Control Bar (9) with one bolt (12) and nut (8). Attach the opposite end of the Control Brace to the Hopper with one bolt (13) and nut (8).



6.

Attach the Rate Gate Control Lever (4) to the Lever Control Bar (9) with 2 bolts (12).



7.

Attach the Accuway® Control Lever (5) to the Control Bar with two bolts (10) that you used in step (6) and fasten with two nuts (8).

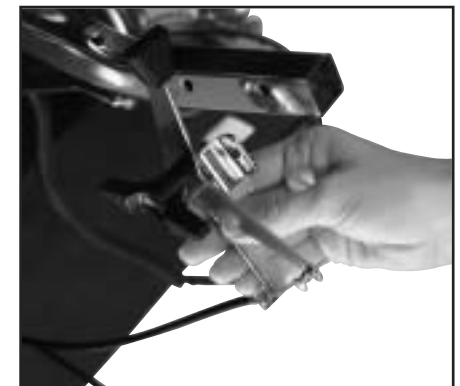

- 8.** Attach Deflector Shield (14) to Frame with two bolts (10) two nylon washers (7) and two nuts (8).



- 10.** Attach the Coupler (15) to Spinner Shaft (16) with Set Screw (17), and opposite end of coupler to shaft on motor.

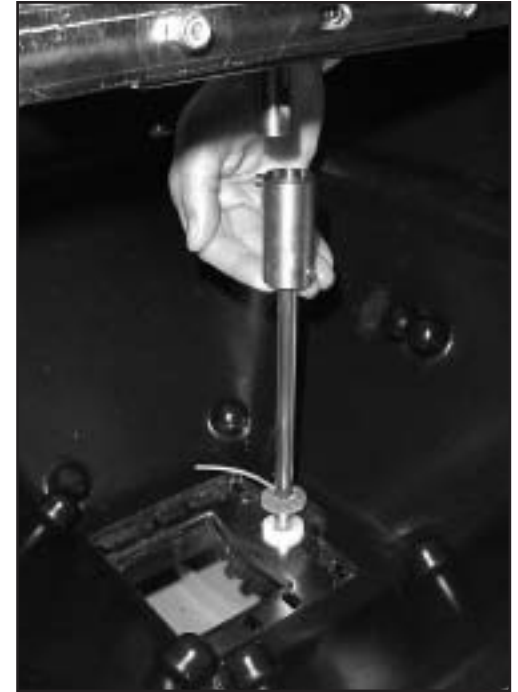

- 11.** Connect the Control Box (18) to the control wire from the motor.



## New Linkage Adjustment Procedure

1. Set regulator dial to 1.
2. Set lever completely to off position.
3. Attach cable clamp (59) to ground prop with 1 1/4" bolt and nut and finger tighten.
4. Route cable through clamp, then through swivel and then tighten the cable clamp bolt just enough to allow the cable to slide back and forth easily.
5. Adjust sheath on cable so there is a 1/8" inch of control wire that is visible between the sheath and the edge of the rate gate linkage.
6. Tighten the cable clamp bolt to secure the sheath.
7. Tighten the screw on the cable fastener to anchor the wire, making sure that the rate gate linkage is pushed up against the dial.
8. Trim excess wire behind cable fastener connector when finished (if necessary).



## Dial Setting Information

The RATE DIAL has 9 numbers with 10 stops between each number, for accurate control of the spreading rate.

The dial is set with only a turn. It will automatically lock into the set position. LINE UP THE DIAL NUMBER WITH THE DIAL INDICATOR.



## Hopper & Frame Assembly

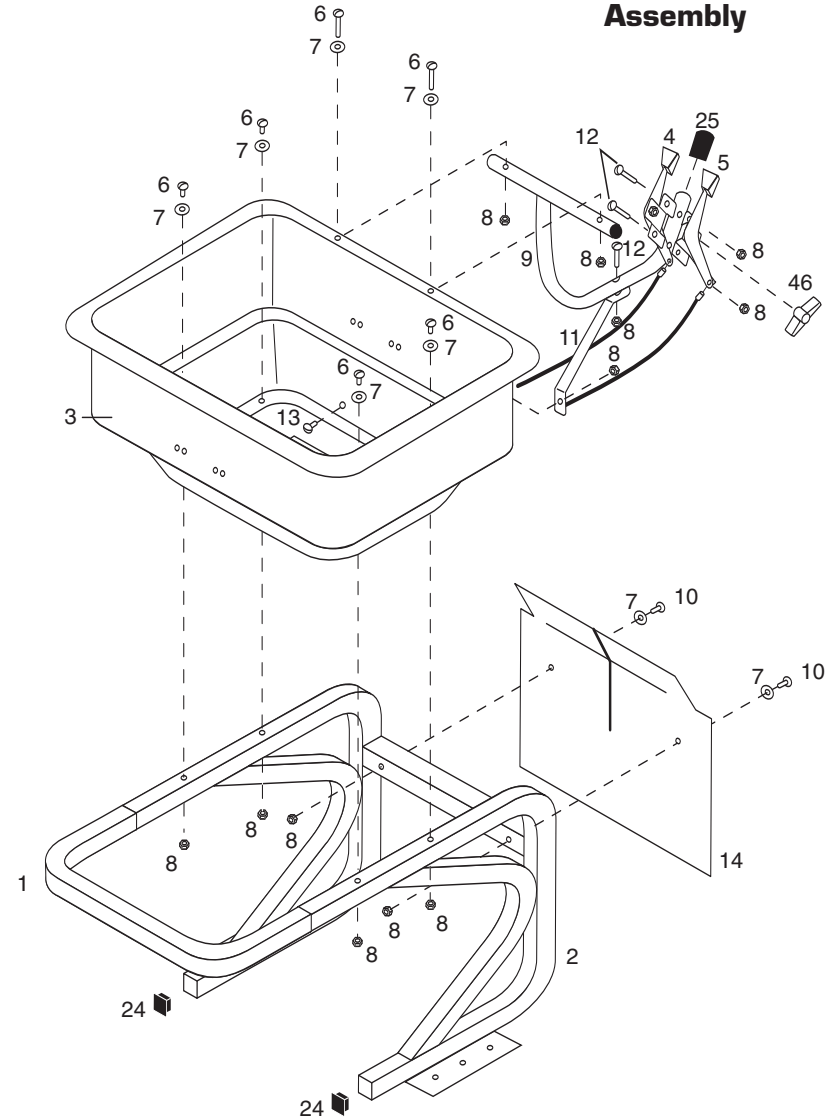

# Exploded View

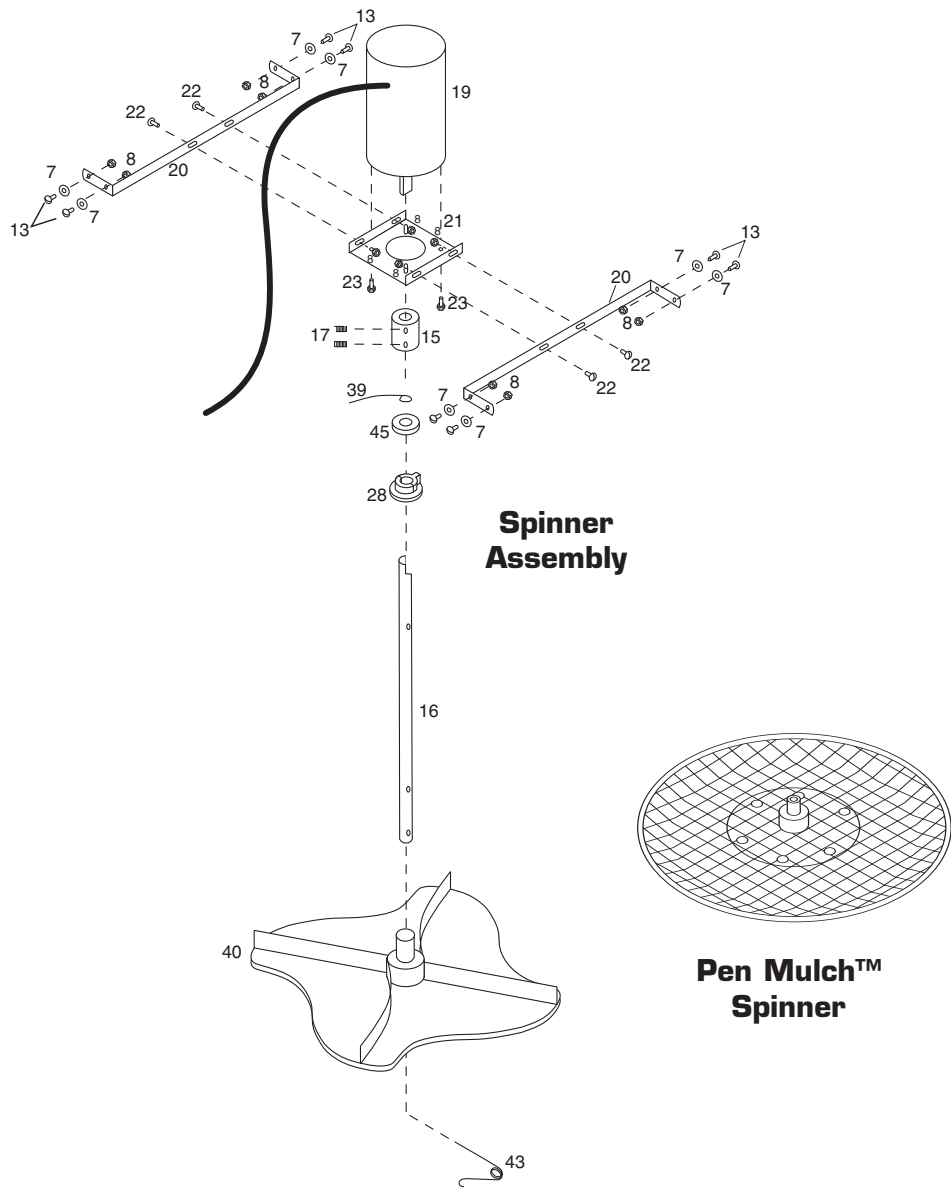

**Spinner  
Assembly**

**Pen Mulch™  
Spinner**

# Exploded View

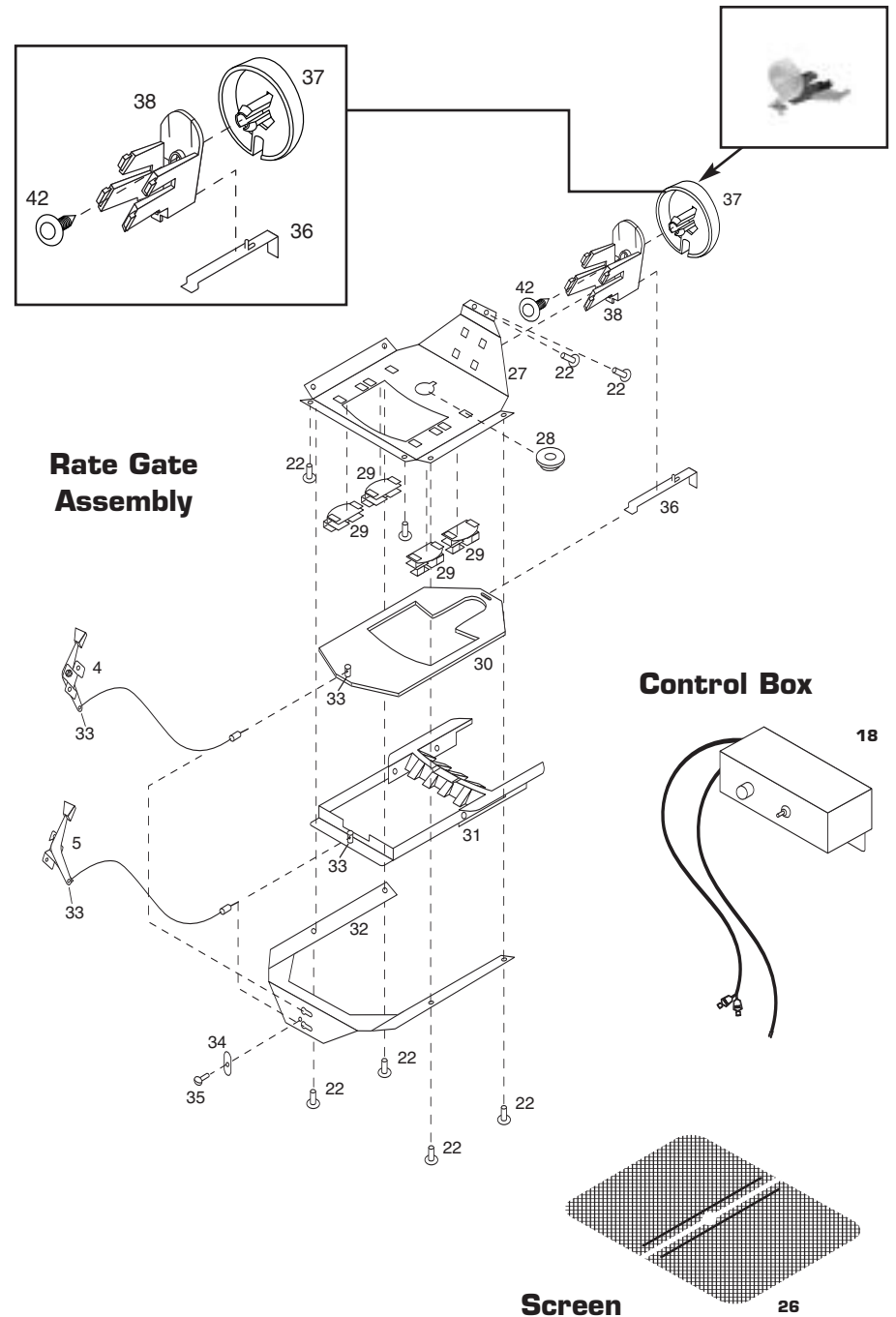

**Rate Gate  
Assembly**

**Control Box**

**Screen**

# Model 120 Parts List

Item #	Part #	Quantity	Description
1	05-298-3030	1	Bump Bar
2	05-120-3010	1	Frame
3	05-120-2212	1	Hopper
4	05-120-3230	1	Rate Gate Control Lever / On-Off
5	05-120-3225	1	Accuway Control Lever
6	05-90-0016	6	Bolt - Hopper to Frame & Lever Control Tube to Hopper 1/4-20 x 2"
7	05-94-0064	17	Nylon Washer
8	SS-91-0004	24	Lock Nut
9	05-120-3030	1	Lever Control Tube
10	05-90-0016	2	Bolt - Deflector Shield to Frame, 1/4-20 x 1 3/4"
11	05-299-3071	1	Lever Control Tube Brace
12	SS-90-0012	3	Bolt -On/Off / Accuway Levers & Brace to Control Tube 1/4-20 x 1 1/2"
13	05-90-0051	9	Bolt - Lever Control Brace to Hopper & Motor Mount Brackets to Hopper 1/4-20 x 3/4"
14	05-120-2211	1	Deflector Shield
15	05-98-0098	1	Spinner Shaft Coupling For New Gear Motor
16	05-120-2235	1	Spinner Shaft
17	05-90-0041	2	Set Screw 1/4-20 x 3/8" Allen / For Spinner Shaft Coupler
18	05-98-0061-W	1	Control Box / Variable Speed
19	05-98-0097-KLA	1	Gear Motor
20	05-120-3020	2	Motor Mount Brackets
21	05-120-2221	1	Motor Mount Base Plate
22	99-10-0205	12	Bolt - Motor Base Plate to Motor Bracket & Hopper Bottom Plate to Hopper 1/4-20 x 1/2" Hex
23	99-10-0205	2	Bolt - Motor to Base Plate 1/4-20 x 1/2" Hex
24	SS-94-0015	2	Plastic Plug to Frame Ends
25	05-94-0023	1	Plastic End Cap / Control Tube End
26	05-120-3310	1	Screen (Optional)
27	05-296-2215	1	Hopper Bottom Plate
28	SS-94-0007	3	Hopper Bottom Bearing
29	05-94-0042	4	Rate Gate & Diffuser Guide
30	05-296-2220	1	Rate Gate
31	05-296-0175	1	Diffuser Assy.
32	05-296-0280	1	Cable Mount Bracket
33	05-90-0044	2	Cable Fastener
34	05-88-2240	1	Cable Retainer
35	05-90-0055	1	Bolt for Cable Retainer 10 - 32 X 1/2"
36	05-296-0110	1	Rate Gate Linkage
37	05-296-0131	1	Dial
38	05-94-0069	1	Dial Mount
39	SS-297-0003	1	Agitator Wire
40	05-220-0140	1	Spinner / Plastic
41	05-296-0115	1	Spinner / Mulch
42	05-94-0078	1	Pine Tree Clip
43	05-97-0031	1	Spinner Clip
44	05-99-0069	1	Hex Key for Spinner Shaft Coupler
45	SS-92-0002	1	Felt Washer
46	05-98-0089	1	T-bar Locking Knob

### Optional Accessories

05-220-0240	Stainless Steel Spinner
05-94-0074	Hopper Cover
05-120-3000	Calibration Tray

# Model 220 Parts List

Item #	Part #	Quantity	Description
1	05-299-3040	1	Bump Bar
2	05-220-3010	1	Frame
3	05-220-2210	1	Hopper
4	05-297-0115	1	Rate Gate Control Lever / On-Off
5	05-297-0110	1	Accuway Control Lever
6	05-90-0038	6	Bolt - Hopper to Frame & Control Tube to Hopper, 1/4-20 x 2"
7	05-94-0064	17	Nylon Washer
8	SS-91-0004	24	Lock Nut
9	05-299-3060	1	Lever Control Tube
10	05-90-0016	2	Bolt - Deflector Shield to Frame 1/4 -20 x 13/4"
11	05-299-3071	1	Lever Control Tube Brace
12	SS-90-0012	3	Bolt - On/Off / Accuway Levers & Brace to Control Tube 1/4-20 x 1 1/2"
13	05-90-0051	1	Bolt -Lever Control Tube Brace to Hopper & Motor Mount Brackets to Hopper 1/4-20 x 3/4"
14	05-220-2250	1	Deflector Shield
15	05-98-0098	1	Spinner Shaft Coupling For New Gear Motor
16	05-220-2225	1	Spinner Shaft
17	05-90-0041	2	Set Screw 1/4-20 x 3/8" Allen For Spinner Shaft Coupler
18	05-98-0061-W	1	Control Box / Variable Speed
19	05-98-0097-KLA	1	Gear Motor
20	05-220-2215	2	Motor Mount Brackets
21	05-220-2221	1	Motor Mount Base Plate
22	99-10-0205	12	Bolt - Motor Base Plate to Motor Bracket & Hopper Bottom Plate to Hopper 1/4-20 x 1/2" Hex
23	99-10-0205	2	Bolt - Motor to Base Plate 1/4-20 x 1/2" Hex
24	05-94-0073	1	Plastic End Cap to Control Tube
25	05-94-0088	2	Plastic Plug to Frame Ends
26	05-220-3050	1	Screen (Optional)
27	05-297-2215	1	Hopper Bottom Plate
28	SS-94-0007	3	Hopper Bottom Bearing
29	05-94-0042	4	Rate Gate & Diffuser Guide
30	05-296-2220	1	Rate Gate
31	05-296-0175	1	Diffuser Assy.
32	05-297-0280	1	Cable Mount Bracket
33	05-90-0044	2	Cable Fastener
34	05-88-2240	1	Cable Retainer
35	05-90-0055	1	Bolt to Cable Retainer 10 - 32 X 1/2"
36	05-296-0110	1	Rate Gate Linkage
37	05-296-0131	1	Dial
38	05-94-0069	1	Dial Mount
39	SS-297-0003	1	Agitator Wire
40	05-220-0140	1	Spinner / Grey Plastic
41	05-296-0115	1	Spinner / Mulch
42	05-94-0078	1	Pine Tree Clip
43	05-97-0031	1	Spinner Clip
44	05-99-0069	1	Hex Key for Spinner Shaft Coupler
45	SS-92-0002	1	Felt Washer
46	05-98-0089	1	T-bar Locking Knob

### Optional Accessories

05-220-0240	Stainless Steel Spinner
05-94-0075	Hopper Cover
05-299-3600	Extension Hopper - Doubles Capacity
05-94-0085	Extension Hopper Cover

**WARNING:** During assembly make sure that all moving parts move freely and are unobstructed by nuts and bolts.

**WARNING: REMEMBER TO ALWAYS KEEP HANDS AWAY FROM MOVING PARTS DURING OPERATION OF THE SPREADER.**

**SPEED - ACCURACY - FREEDOM FROM STRIPES AND STREAKS are yours - when you use this Spreader.**

The spread width ranges from 6 ft. to 25 ft. wide, depending on the volume/density, particle size of the material and the rate of travel.

The spread thins or feathers at the outer edges, eliminating sharp, "Edge of spread" lines which cause stripes and streaks. Extra coverage can be given under trees and other heavy feeding areas without showing "edge of spread" lines.

Gaps and double overlaps are less likely. Small errors in travel are forgiven and do not show.

**WARNING: When spreading products containing herbicides, exercise extreme caution with respect to careless spreading and to wind-drift.**

**CONTACT OF SOME PRODUCTS ON SOME PLANTS CAN BE FATAL.**

If a dial setting is not found, use the size and weight comparison table found on the back page.

Determine a dial setting on the low side. If the setting proves to be too low, cover the area more than one time. A higher setting can be used when a proven dial setting is established.

REMEMBER - Published dial settings can be approximate only. The operation of the spreader, the condition of the material (damp or dry or over-pulverized) and weather conditions, are all contributing factors.

For these reasons, it's often a good idea to spread the area 2 times - at one-half rate - in cross directions (SEE INFORMATION ON ONE-HALF RATE DIAL SETTINGS ON REFERENCE CHART ON THE BACK PAGE. SPREADING AT ONE-HALF RATE DIAL SETTINGS IS HIGHLY RECOMMENDED UNDER DAMP & HUMID CONDITIONS.

**BECOME FAMILIAR WITH THE OPERATION OF THE SPREADER BEFORE YOU PUT MATERIAL IN THE HOPPER.**

Travel at a constant speed and operate the spreader in a level position.

**Remember:** Open the rate gate **after the spreader is turned on** at operating speed.

Close the rate gate while spreader is **still at operational speed.**

## Rotary Agitator

Use the rotary agitator only if needed. Free-flowing, lump-free materials will not require the agitator. The rotary agitator is easily installed or removed. Note the clockwise rotation & sweep. Place felt washer around spinner shaft before inserting agitator. - See page 7.

## OIL BEARINGS AND ALL MOVING PARTS

Make certain the spreader is running freely!

## Now You are Ready to Put Material in the Hopper

- Make certain the *rate gate* is in closed position.
- As insurance against spill damage and spill loss, put material in the hopper with the spreader on a walk, driveway, paper, plastic, etc.

## Now You are Ready to Spread

- Spread header strips at the ends of the area OPPOSITE the direction of spreading. This will provide a "turn-around" area, an area to re-align the spreader for the return spread.
- Example is for 6 ft. wide spread: Make the first spreading pass at one-half the spread width from the edge of the spreading area or in this case approximately 3 feet or one big step.
- Additional spreading passes will be at the full spread width or approximately 6 feet apart.
- TAKE A SIGHTING AT THE FAR END. Keep your eye on the sighting as you spread. You will not need to wonder where you are or where you have been. Continue until spreading is completed.
- Left over fertilizer can be spread under trees and other high feeding areas without showing "edge of spread" lines.

## Cleaning the Spreader is Part of the Spreading Job.

IMMEDIATELY AFTER USE - CLEAN AND OIL THE SPREADER

- **Method #1** - Wipe spreader thoroughly with an oily cloth. Oil all bearings and bearing areas.
- **Method #2** - Wash, rinse, and dry the spreader. Note: Drying takes time. (Moisture trapped in bearing areas is slow to go.) Immediately after drying - oil all bearings and moving parts. Make certain all operations are thorough.

Note: Good "Dry Cleaning" is preferable to poor "Wet Cleaning".

- It is virtually impossible to have rust and corrosion on a clean, dry, oiled surface.
- Again - just before using - oil all bearings and moving parts.
- In storage, ideally the spreader should be hung by the handle. In any case, do not pile weight on the spreader, as excess weight over a period of time can distort the tires.

## "Accuway" Use Instructions.

BALANCING THE SPREAD - A COMPLICATED PROBLEM WITH A SIMPLE SOLUTION

HERE'S THE PROBLEM - IT'S THE VARIABLES

It's the **VARIABLES**. Each variable has it's own spread pattern characteristics.

It's the **VARIABLES**. They're transposed and mirrored in the Spread pattern.

TRAVEL SPEED, HUMIDITY AND CONDITION OF PRODUCT ARE  
MAJOR FACTORS IN **BALANCING THE SPREAD**

"To Every Action There Is Always An Opposed and Equal Reaction"  
(Newton's law of motion - Sir Isaac Newton, 1642-1727.)

## Accuway - What It Does



Accuway Spread Pattern Equalizer Balances the spread pattern - Bulls Eye - Dead to the Center of the Spreader. All products. All spreading conditions. Skewing is eliminated. Does not change the spread width.

**VARIABLES** in product, weather, spreading equipment, spreader operator, etc., and combinations of **variable** elements produce **VARIABLES** in the spread pattern.

- **VARIABLES** include product size, weight, shape, surface finish, hygroscopic or non hygroscopic composition, condition of product (exposure to humidity, temperature, etc.)
- **VARIABLES** include spreading rate (light, medium, heavy).
- **VARIABLES** include size, shape, design of spreading spinner.
- **VARIABLES** include product dispensing on spreading spinner.
- **VARIABLES** include condition of the spreader end the spreading spinner (product build up on the casting vanes, etc.)
- **VARIABLES** include operator habits, fast or slow walking, tilting spreader forward or backward or operating spreader in a level attitude.

## Accuway - How It Works

A slight movement of the Accuway control lever (see illustration below) factors the variables.







Shifts the product placement on the spreading spinner.

This in turn balances the spread pattern heavier to right or heavier to left as required.

Adjustment is very sensitive.



Dial settings are approximate only.

Product	Lbs. per 1000 Sq. Ft.	Full Rate	Half Rate
	1	3.6	3.1
	2	4.0	3.5
	3	4.2	3.7
	2	3.7	3.2
	4	4.7	4.1
	6	5.2	4.5
	2	3	2.2
	4	4.2	3.7
	6	4.5	4
	1	3.5	3
	2	4.2	3.7
	3	4.7	4
	2	3.5	3
	4	4.2	3.8
	6	5.2	4.5
	2	3.5	3
	4	4.2	3.8
	6	5.2	4.5
	2	3.8	3.3
	4	4.9	4.1
	6	5.9	4.9

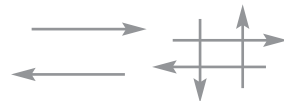

## Models 120 and 220

### Spyker Mulch-n-more Spreaders

There are a variety of optional attachments for the model 120/220...

- 1. Mulch Spinner Blade...** Used for spreading a variety of products from Pellet Mulch such as PennMulch® to Dry Sand, Salt and other difficult to spread high volume or large particle products. With Spyker's patent pending removable spinner blade you can change to Mulch blade in a matter of seconds. All other spreaders that are on the market require the removal of the hopper to access the spinner blade which can take as long as 1/2 to 1 hour to do. No other spreader company manufactures a "mulch basket spinner blade" for use with high volume products.
- 2. Calibration Pan...** Used for calibrating the turf product for accurate spreading to reduce waste and increase effectiveness of the product. This is the latest, greatest attachment for the 120/220 series. Calibrate without moving the spreader.
- 3. Border Patrol...** Used for guarding collars, greens, flower beds, driveways and sidewalks from fertilizer or pesticide materials. Stop flow to one side. Easily turned on and off with your foot while continuing to spread.
- 4. Barrier Shield...** For use with ice melt products and salt to deflect the product down on to the sidewalk (3' width pattern) essentially converting the rotary spreader to a drop spreader for sidewalks.

## THERE'S MORE TO A SPREADER THAN MEETS THE EYE — LOTS MORE

**Spreadability** - Dial-a-matic regulator ensures exact spread rate. Accuway® Spread Pattern Equalizer assures exact placement of the spread pattern - Bull's Eye - dead to the center of the spreader. All products - All spreading conditions. Skewing is eliminated.

**Durability** - Model 120/220 spreaders will survive use and abuse. Welded stainless steel construction is double braced. Guaranteed metal gears.

**Reliability** - You can count on. Accuway® spread control system is so innovative, it's patented. Is so successful it's used on all Spyker 120/220 spreaders.

A complicated problem is solved with a fundamental solution.

(Newton's law of motion: To every action there is always an opposed and equal reaction.)

**Serviceability** - 24 hour replacement parts service available direct from the factory. Model 120/220 spreaders shipped set up except control bar and the hopper connection to the frame.

## Broadcast Spreading



Broadcast spreading is as old as early man. In the early days of agriculture, field seeding was accomplished with hand cast broadcast. The hand cast method of seeding was a limited factor in growing field crops that were hand seeded.



Mechanized casting came into being in 1868 when Samuel Speicher invented the Hand Crank "Cyclone" Seeder.

The seed sower was a breakthrough in field seeding. It was hailed as a major advancement in agricultural implements.



Paul Speicher put the hand crank seeder on wheels in 1955.

This development ushered in a new era in spreading and spreading products. New products and product forms adapted to broadcast spreading were developed.



In 1988 a new dimension was added to broadcast spreading - SPREAD PATTERN CONTROL - a dead center spread pattern equalizer.

Spyker's Accuway® spread pattern equalizer solves a complicated problem with a fundamental patented solution.

## Accuway Control' Instructions

Calibrating your Spyker Electric 120 and 220 Broadcast Spreaders...

1. Dial your recommended setting (or use the "Calibration Pan" to find the most accurate setting for that particular product).
2. Start with the 'Accuway control lever' up or forward.
3. Begin to spread your product. As you are spreading you should be able to see the spread pattern in front of you. Generally, all spreaders will tend to throw fertilizer heavy to the right. As you continue to spread, (using the left lever) Accuway control, pull the Accuway control towards you very slowly\* until you begin to bring the spread pattern dead center in front of you.
4. Once you have the spread pattern 'dead center', leave the left lever alone for the rest of the time you are spreading that particular product. There should be no reason to re-set the Accuway for that product unless you see that the spread pattern has changed due to bumping the lever. If it has changed slightly simply re-adjust the pattern while you're spreading.

**Note** \*"slowly" means as little as 1/100 of an inch at a time. It will not take much to change the pattern. If you radically move the left lever Accuway control, you may impede or shut off the flow of fertilizer or lose the Accuway position and it will be necessary to push the lever all of the way forward and begin to bring it back towards you slowly until the pattern is set again.

## Operating at the Mulch Setting

1. You will notice a slot in the spreader setting dial control right where the 9 is or was located. Simply dial the setting so that the metal guide will go through this dial slot when you move the right control lever.
2. The spreader opening will now move all of the way open to the maximum opening that the spreader can achieve.
3. This setting was basically designed to spread PennMulch® at 70-75 lbs. per thousand square feet at 2.5 miles per hour. It's easy enough to check and adjust your walking speed. See Mulch-n-More calibration instructions "Calculating your walking speed".
4. The "all of the way open setting" can also be used to spread dry sand, dry organic top dresses and fertilizers, salt and ice melt products and other normally difficult to spread products.
5. When using the mulch setting you can gate the flow of the material as you're spreading. For salt, sand and top dress materials in which an accurate setting is not critical simply watch the flow of material as it comes out of the spreader. Either open more or close off (gate the flow) until you feel comfortable with the amount of material you are spreading. If you would like to check the flow rate simply mark the position of the control lever with a piece of tape and use the calibration bucket to check the coverage per thousand square feet. (See the calibration instructions included with the calibration bucket or "Calibrating the Mulch-n-More" on the [www.spyker.com](http://www.spyker.com) web site.)
6. Through trials involving mass flow products such as sand and salt we have found that using the "mulch basket" gives you the best spread pattern. Although the spread will be slightly to the right using the mulch basket, the actual spread of the product is even all of the way across the effective spread width. Depending on the type of product you're spreading, using a standard spinner blade the product will flow heavy to the left and give you a less than desirable spread pattern leaving a heavy line of product a one spot and light at another. This is the exact reason Spyker developed the Mulch spinner blade. No other ground driven spreader has the capability of spreading materials at these high rates because they all use a standard spinner blade.

## Changing the Spinner Blade

1. Simply remove the special "spring pin" from the spinner shaft that holds the regular spinner blade onto the spinner shaft. Lift the stainless collar that holds the shaft together.
2. Slide the shaft upwards a few inches and remove the blade from the shaft.
3. Slide the Mulch Basket onto the shaft, slide the collar back onto the shaft under the blade, re-connect the shaft and slide the collar over the break in the shaft.
4. Put the "spring pin" in the lower hole on the shaft (for the Mulch Basket) and clip the spring onto the shaft using the hook. The "spring pin" holds the spinner blade in place and stops the collar from moving upwards so that the shaft will not separate.
5. Reverse instructions for replacing the regular spinner blade. The only difference would be that you must pin the regular blade using the upper hole on the spinner shaft. It's easy. The upper hole is for the regular spinner blade, the lower hole is for the Mulch Basket.

## LIMITED WARRANTY

This is warranted to the original purchaser only, other than used commercially, against defects in materials and workmanship, for a period of ninety (90) days from the date of purchase.

*\* For Spyker Spreaders LLC, products employing metal gear systems, pinion and bezel, these metal gears, only not inclusive of any other parts or materials, are warranted for the life of the spreader, not to be used for replacement or repair past original purchase.*

Spyker Spreaders LLC, will not be liable for any loss, damage or expense including, but not limited, consequential or incidental damages, arising from the operation, condition or use of the item, the sole and exclusive remedy against Spyker Spreaders LLC, being the replacement of the defective parts. This warranty gives you specific legal rights and you may also have other rights which vary from state to state.

THIS EXPRESS WARRANTY, WHICH IS APPLICABLE ONLY TO THE ORIGINAL PURCHASER, IS IN LIEU OF AND EXCLUDES ALL OTHER WARRANTIES, WHETHER EXPRESSED OR IMPLIED BY OPERATION OF LAW OR OTHERWISE, INCLUDING ANY WARRANTY OF MERCHANTABILITY OR FITNESS FOR PARTICULAR PURPOSE.

**Spyker Spreaders LLC**

P.O. Box 7 • 140 Mill St. • Urbana, IN 46990  
U.S.A.

MODEL 179



## FEATURES & BENEFITS

**"ACCUWAY" Spread Pattern Equalizer ENSURES spreading dead center of the spreader. (Indicated with "22" in model number)**



20 SERIES

**Gears are unconditionally guaranteed ENSURES trouble free operation.**

**Dial-A-Matic spread rate control ENSURES spreading at exact spread rates.**

90 SERIES



**Optional BORDER PATROL spread pattern cut-off prevents spreading on drive-ways, flower beds, etc.**

MODEL 88



**Extension hoppers available for models 220, 299 and 20 Series spreaders.**

**Shipped Set-Up. Saves time and labor ENSURES proper assembly. (except #64)**

MODEL 298  
Mulch Spreader

**Stainless steel frames ensure longer spreader life, easier maintenance and present a quality image.**

MODEL 299  
Mulch Spreader



**High grade plastic non-corroding wheels with nylon bearings, no lubrication required, ENSURES trouble free maintenance.**

**P.O. Box 7 • 140 Mill Street • Urbana, IN 46990 USA  
1-800-972-6130 • Fax 260-774-3416**